



Neutronics
Gas Analysis Solutions

Instruction manual Model 3100

Oxygen analyzer / controller
Trace to percent O₂ measurement
0.1 PPM to 100% range



Manual file name: MN-A-0005
Revision Level: C
Manual Part Number: C5-06-4900-16-0
Revision date: December 22, 2016

Table of Contents

Welcome	iv
Notice	iv
Safety instructions.....	v
Designated use	v
Operational safety.....	v
1 Introduction.....	1
1.1 Functional overview	1
1.2 Features	1
1.3 System hardware overview	2
1.3.1 Main board	2
1.3.2 Relay board	2
1.3.3 Power supply board	2
1.3.4 Display board	2
1.3.5 Control panel.....	2
1.3.6 Chassis.....	3
1.3.7 Sensor	4
1.3.8 Remote sensor module (RSM).....	4
1.4 Analyzer inputs and outputs.....	5
1.4.1 Remote sensor module (RSM) interface.....	5
1.4.2 Alarm-1 relay output.....	5
1.4.3 Alarm-2 relay output.....	5
1.4.4 Fault relay output.....	5
1.4.5 Heater OK output	6
1.4.6 Analog voltage output	6
1.4.7 Analog current output.....	6
1.4.8 Range ID output	6
1.4.9 Service port	6
1.5 Control panel user interface	7
1.5.1 “UP” pushbutton	7
1.5.2 “DOWN” pushbutton.....	7
1.5.3 “MODE” pushbutton	7
1.5.4 7-Segment alphanumeric display	7
1.5.5 RUN indicator LED	7
1.5.6 Alarm-1 indicator LED	7
1.5.7 Alarm-2 indicator LED	7
1.5.8 Fault indicator LED.....	7
2 System installation and start-up.....	8
2.1 Installing the analyzer	8
2.1.1 Step 1 – Locate the Model 3100 analyzer	8

2.1.2	Step 2 – Install the remote sensor module (RSM)	9
2.1.3	Step 3 – Install the analyzer	9
2.2	Step 3 – Start up and commissioning	13
2.2.1	Power up check list	13
2.2.2	Step 1 -- Power up the unit	13
2.2.3	Step 2 -- Calibrate the unit	14
2.2.4	Step 3 –Set Alarm-1 and Alarm-2	14
3	Operation	15
3.1	Overview	15
3.2	User modes	15
3.2.1	Calibration	16
3.2.2	Set/view ALARM-1 mode	17
3.2.3	Set/view ALARM-2 mode	17
3.2.4	View active faults mode	17
3.2.5	Return to RUN mode.....	18
3.3	System modes.....	18
3.3.1	Self-test & warm-up mode.....	18
3.3.2	RUN mode.....	18
3.3.3	ALARM-1 Active mode.....	19
3.3.4	ALARM-2 Active mode.....	19
3.3.5	FAULT Active mode	19
4	Setup, maintenance, and troubleshooting	20
4.1	System setup.....	20
4.1.1	System setup via control panel keypad	20
4.1.2	System setup via RS-232 service port.....	24
4.1.3	Change factory settings via hardware jumpers.....	34
4.2	Routine periodic maintenance.....	36
4.3	Troubleshooting.....	37
4.3.1	Fault codes.....	37
5	Appendices	39
5.1	Appendix A – Spare parts list.....	39
5.2	Appendix B – Specifications.....	39
5.3	Appendix C – Analyzer factory configuration settings	41
5.4	Appendix D – Control panel hot-key functions.....	42
5.5	Appendix E – Range / output chart	42
6	Limited warranty	43

Welcome

The Model 3100 analyzer is a compact microprocessor controlled instrument designed for oxygen measurement. This manual provides detailed information on how to operate and maintain the Model 3100 analyzer from Neutronics.

For additional information regarding the maintenance and service of the Model 3100 analyzer, please contact the technical support team at Neutronics. If you have questions or comments, we would like to hear from you.

Neutronics Inc.
Gas Analysis Solutions
456 Creamery Way
Exton, PA 19341
Tel: +1-610-524-8800
Toll Free: 800-378-2287 (US only)
Fax: +1-610-524-8807
EMAIL: info@neutronicsinc.com

Equipment Serial Number: _____

Notice

Product improvements and enhancements are continuous; therefore, the specifications and information contained in this document are subject to change without notice.

Neutronics, Inc. shall not be liable for errors contained herein or for incidental or consequential damages in connection with the furnishing, performance, or use of this manual.

No part of this document may be photocopied, reproduced, or translated to another language without the prior written consent of Neutronics, Inc.

This work is protected under Title 17 of the US Code and is the sole property of Neutronics Inc. No part of this document may be copied or otherwise reproduced, or stored in any electronic information retrieval system, except as specifically permitted under US copyright law, without the prior written consent of Neutronics Inc.

Copyright ©2016 Neutronics Inc.

Safety instructions

WARNING

- ▶ Installation, operation, and maintenance of the unit must be performed by trained technical personnel.
- ▶ Technical personnel must be authorized to perform the tasks by the owner-operator.
- ▶ Electrical connections must be established by an electrical technician.
- ▶ To prevent personal injury, technical personnel must read, understand, and follow all warnings and instructions in this manual before attempting installation or operation of the unit.
- ▶ If the operator cannot read these instructions, operating instructions and safety precautions must be read and discussed in the operator's native language.
 - Si el operador no puede leer las instrucciones, las instrucciones de operación y las precauciones de seguridad deberán leerse y comentarse en el idioma nativo del operador.
 - Si l'utilisateur ne peut lire les instructions, les instructions et les consignes de sécurité doivent lui être expliquées dans sa langue maternelle.
- ▶ No operator access is permitted inside the housing. Repairs not described in the Operating Instructions may only be performed by the manufacturer or authorized service team.

Designated use

- ▶ The analyzer is a microprocessor-based instrument for oxygen measurement in clean gas applications. It is designed to minimize all effects of static discharges and interference from RFI and EMI emissions.
- ▶ If the equipment is used in a manner other than as described, the protection provided by the equipment may be impaired and may pose a threat to the safety of personnel.
- ▶ The manufacturer does not accept liability for damage caused by improper or non-designated use.

Operational safety

CAUTION

- ▶ Follow all local standards, safety regulations, and installation guidelines. Observe proper safety procedures when working with pressurized gases.
- ▶ Mount the unit in a manner that will guard against excessive vibration, collapse, and exposure to liquids, flammable gases, flames, or high temperatures.
- ▶ Mount the unit in an area of free airflow to prevent the enclosure from exceeding the operating temperature specifications. Do not mount the analyzer against hot surfaces. Do not block the ventilation openings on the analyzer enclosure.
- ▶ Do not expose the Model 3100 enclosure to water, high humidity or moisture. The analyzer enclosure is not watertight.
- ▶ Do not expose the Model 3100 to flame or high temperatures.
- ▶ Do not expose the Model 3100 to flammable gases or vapors. The unit is not rated explosion proof or intrinsically safe.
- ▶ Ensure that the pressure of gas entering the remote sensor module (RSM) is compatible with the operating instruction. Do not exceed 6 PSIG.
- ▶ Do not expose the unit directly to an unregulated gas supply. High gas pressures may cause a failure in the sampling system.
- ▶ The unit operating voltage is: 110/208 VAC $\pm 10\%$, 50/60Hz, 3.5A, single phase, 3-wire or 11-30 VDC 3 watts. Failure to use the proper operating power may result in damage to the unit.
- ▶ The power cord is the disconnecting device. Do not position the equipment so that it is difficult to remove the power.
- ▶ Prior to commissioning, check that all connections are correct. Calibrate the unit at an equivalent pressure and flow rate to the measured gas before use.

1 Introduction

1.1 Functional overview

The Neutronics Model 3100 *Compact Series* analyzer is a microprocessor-based instrument for oxygen measurement and process control applications.

The Model 3100 analyzer is designed for use with a separate Neutronics Remote Sensor Module (see Figure 1). The RSM features the Neutronics ZR100 rapid-response zirconium oxide (ZrO₂) oxygen sensor, a ceramic, solid-state device with an extremely fast response to oxygen, a wide measurement range, and a robust design. It is responsive to changes in the partial pressure of oxygen of a sampled gas in the range of 0.1 PPM to percent concentration of O₂. Unaffected by dry atmospheres and extremely cold storage temperatures (or power down situations in cold environments), it has an indefinite shelf life.

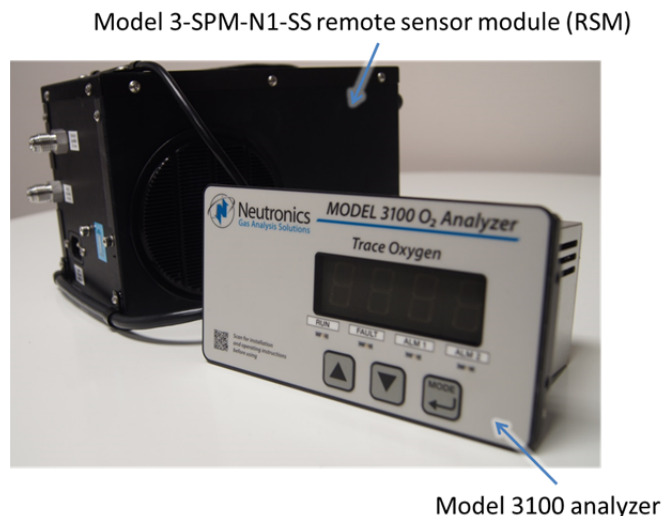

Fig. 1, Analyzer with RSM

1.2 Features

The *Compact Series* analyzer modules are designed to be flush mounted onto the surface of a control panel or console. The separate Remote Sensor Module can be mounted close to the sampling point to ensure the fastest response possible. Other key features include:

- 0.1 ppm to percent measurement range
- Two user-adjustable oxygen alarms with configurable relay outputs for process control use
- Two analog outputs: 4-20 mA and 0-1, 0-5, or 0-10 VDC
- Auto-ranging or fixed range oxygen measurement (VDC output provided for auto-range identification)
- RS-232 digital interface

1.3 System hardware overview

1.3.1 Main board

The main board (see Figure 2) houses the microprocessor and supporting electronics for controlling the operation of the Model 3100 Analyzer. The main board receives the sensor input and provides the control and display functions of the analyzer.

1.3.2 Relay board

The relay board (see Figure 2) houses relay contacts for all of the alarm and control features. The relays are mapped discretely to each alarm to provide electrical outputs for reporting and process control use.

1.3.3 Power supply board

The power supply board (see Figure 2) is designed for 110/208 VAC, 50/60 Hz mains power input. The power supply is fused directly to the board.

1.3.4 Display board

The display board (see Figure 2) is designed to generate a digital indication of the oxygen concentration (see Appendix E – range / output chart) and fault codes (section 4.3.1). The display is a 7-segment, 0.75" alphanumeric LED.

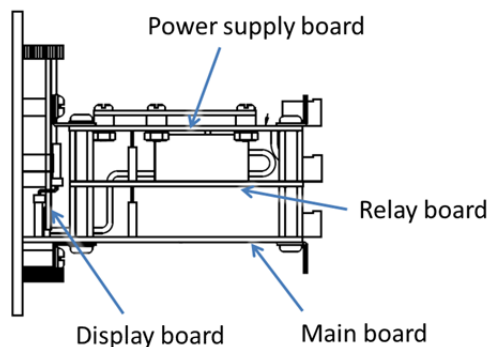

Fig. 2, Board configuration

1.3.5 Control panel

The control panel (see Figure 3) serves as the main user interface. It features the menu-driven pushbutton keypad (ramp-UP, ramp-DOWN, and MODE keys) and the status LED's. Designed to be splash and water-resistant, it includes four (4) #8-32 threaded mounting studs at each of the corners and a gasket for use in mounting the module to a stationary control or equipment panel. The faceplate rating is NEMA 4, IP66.

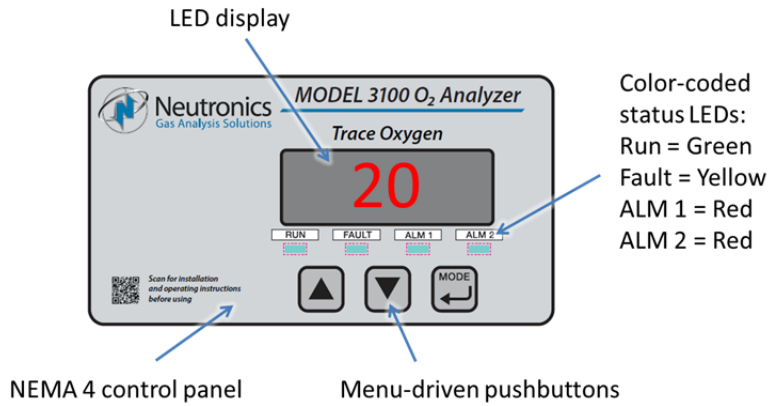

Fig. 3, Control panel

1.3.6 Chassis

The stainless steel chassis or electronics enclosure (see Figure 4) is designed to provide a general level of protection against mechanical damage from the local environment. It is an important part of the electrostatic discharge (ESD) shielding design. Since it is a flush mounted unit, the instrument components housed in the chassis will be located behind the user’s control panel or embedded within an equipment enclosure. The chassis is rated NEMA 1, IP20, for general purpose. It is not watertight.

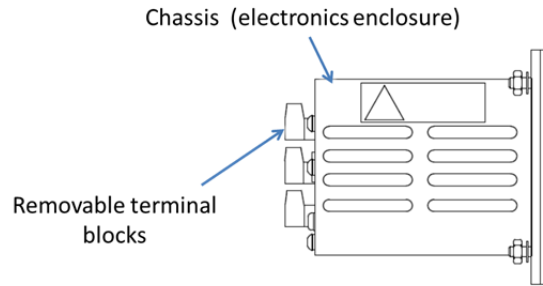

Fig. 4, Chassis side view

The rear of the electronics enclosure (see Figure 5) includes removable plug-in type terminal blocks and the RSM interface cable connector.

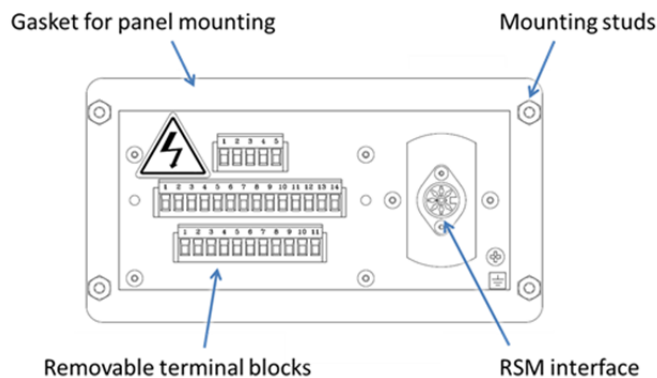

Fig. 5, chassis rear view

1.3.7 Sensor

The Neutronics ZR100 rapid-response zirconium oxide sensor is a solid-state ceramic device. When heated in its unique oven, it produces a predictable electrical output in response to changes in the partial pressure of oxygen of a sampled gas, ranging from 0.1 PPM to percent concentration of oxygen. The most notable advantage of the ceramic sensor technology is its ability to rapidly measure oxygen through large step changes in concentration. The ZR100 sensor can accurately measure PPM concentrations of oxygen within seconds after exposure to air.

1.3.8 Remote sensor module (RSM)

The separate remote sensor module (RSM) houses the sensor, the heater assembly, and the delivery system for the gas sample. Gas is directed in a continuous flow through the sampling system to the oxygen sensor. The sensor determines the oxygen concentration of the gas in real time. The RSM is an integral part of the Model 3100 analyzer system (see Figure 6). It is available in two (2) configurations: pump-driven and positive pressure-driven. Refer to the Remote Sensor Module instruction manual for more details.

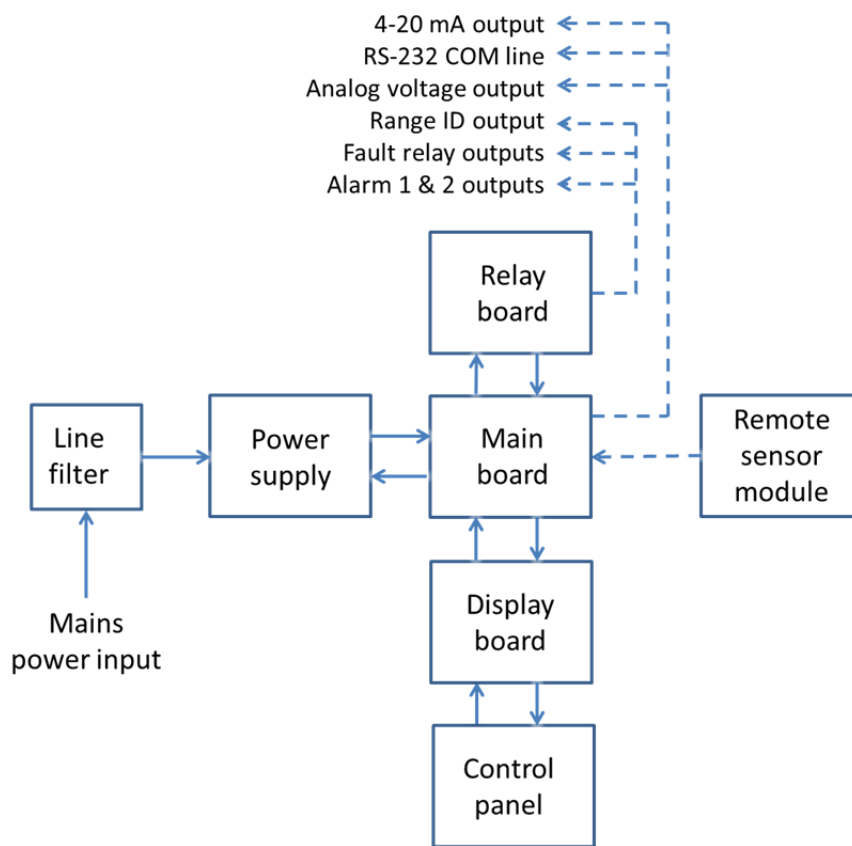

Fig. 6, System configuration

1.4 Analyzer inputs and outputs

1.4.1 Remote sensor module (RSM) interface

A single multi-signal electrical interface (connector) on the back of the Model 3100 analyzer is used to connect the RSM to the analyzer (see Figure 5). It includes the oxygen sensor input, the sensor heater thermocouple input, and the sensor heater control output.

1.4.1.1 The oxygen sensor input

The oxygen sensor input is an electrical interface used to indicate the oxygen concentration in the measured process or in a test gas. It is proportional to the oxygen present in a sampled gas stream.

1.4.1.2 The sensor heater thermocouple input

The sensor heater thermocouple input feeds back a voltage to the Model 3100 analyzer proportional to the sensor heater temperature. The Model 3100 uses that electrical output to control the sensor heater temperature within $\pm 0.2^\circ\text{C}$.

1.4.1.3 Sensor heater control output

The sensor heater control output is a variable frequency control signal, based on the sensor heater thermocouple input voltage. It controls the sensor heater to operating temperature by varying its average VAC mains power level continuously. This method of control maintains the oxygen sensor operating temperature to within its narrow specification at all times, ensuring reliable performance.

1.4.2 Alarm-1 relay output

The Alarm-1 relay is mapped to the Alarm-1 setpoint. The user may set the oxygen level at which Alarm-1 activates (see section 3.2.2). Alarm-1 may be configured as ascending (highest oxygen level allowable) or descending (lowest oxygen level allowable) activation. The relay output may be configured for fail-safe (relay coil de-energized in alarm state) or non-fail-safe (relay coil energized in alarm state) activation. Factory default settings are ascending, and fail-safe (see Appendix C, Factory Configuration). The Alarm-1 relay contacts are Form C (DPDT), voltage-free.

1.4.3 Alarm-2 relay output

The Alarm-2 relay is mapped to the Alarm-2 setpoint. The user may set the oxygen level at which Alarm-2 activates (see section 3.2.3). Alarm-2 may be configured as ascending (highest oxygen level allowable) or descending (lowest oxygen level allowable) activation. The relay output may be configured for fail-safe (relay coil de-energized in alarm state) or non-fail-safe (relay coil energized in alarm state) activation. Factory default settings are ascending, and fail-safe (see Appendix C, Factory Configuration). The Alarm-2 relay contacts are Form C (DPDT), voltage-free.

1.4.4 Fault relay output

The Fault relay output is used to indicate that there is at least one system fault active on the Model 3100 analyzer (see section 4.3.1). The relay output activation is non fail-safe, and is not configurable. The Fault relay contacts are Form B (SPST), voltage-free.

1.4.5 Heater OK output

The Heater OK output relay is a system diagnostic used to indicate that the Model 3100 has detected a sensor heater temperature that is not within specification tolerance (see section 4.3.1 – Fault Codes and Definitions). The relay output activation is non fail-safe, and is not configurable. The Heater OK relay contacts are Form B (SPST), voltage-free.

1.4.6 Analog voltage output

The analog voltage output is a dynamic potential used to indicate to a remote device the displayed oxygen concentration during normal analyzer operation and system maintenance. The Analog voltage output follows the oxygen readout displayed on the 7-segment LED display during all system and user modes except for user setup. For a complete listing of available output levels by analyzer range, refer to Appendix E – range / output chart.

The analog voltage range can be adjusted by the user (section 4.1 – system setup). Available settings are 0-VDC for minimum-scale-deflection or 1, 5 or 10-VDC full-scale. The factory default setting is 0-1 VDC (see Appendix C, Factory Configuration). The analog voltage output is scaled according to the analyzer's selected range and must be used in conjunction with the Range ID voltage when the analyzer is configured for auto-ranging (see section 1.4.8).

1.4.7 Analog current output

The analog current output is a dynamic current flow used to indicate to a remote device the displayed oxygen concentration during normal analyzer operation and system maintenance. The analog current output follows the oxygen readout displayed on the 7-segment LED display during all system and user modes, except for user setup. For a complete listing of output levels by analyzer range, refer to Appendix E – range / output chart.

The minimum scale deflection may be set to either 0 mA or 4 mA. Full-scale is fixed at 20 mA. The analog current output is scaled according to the analyzer's selected range and must be used in conjunction with the Range ID voltage when the analyzer is configured for auto-ranging (see section 1.4.8).

1.4.8 Range ID output

The Model 3100 can be configured by the user to automatically switch its measurement range, based on the concentration of oxygen measured while in-service, to provide the most accurate and highest possible resolution outputs. For a complete listing of analyzer ranges, refer to Appendix E – range / output chart.

Remote auxiliary devices designed to interpret the Model 3100 analog outputs over multiple output range scales require an indication of the analyzer's selected range at all times for accurate scaling. The Model 3100 features a 0-10 VDC auto-range identification output. The range ID output is used in conjunction with the analog voltage and analog current outputs when auto-ranging is used. It provides an indication of the analog outputs' selected full-scale. There are four range ID voltage levels used in the 3100 to correspond with its four output ranges (Appendix E – range / output chart).

1.4.9 Service port

The RS-232 service port provides a user-friendly means of digital communication with the Model 3100 analyzer. Through this port, the unit may be configured, calibrated, and queried for most functions. The RS-232 port may also be programmed to send out information on a timed basis. Additionally, the service port may be used with a PC based computer (such as a portable notebook computer) over a standard bi-directional RS-232 serial interface.

1.5 Control panel user interface

1.5.1 “UP” pushbutton

The “UP” pushbutton can be used to program the Model 3100 via the control panel. This momentary push-button soft key is used to select the next option or value. This function is menu-driven.

1.5.2 “DOWN” pushbutton

The “DOWN” pushbutton can be used to program the Model 3100 via the control panel. This momentary push-button soft key is used to select the preceding option or value. This function is menu-driven.

1.5.3 “MODE” pushbutton

The “MODE” pushbutton can be used to program the Model 3100 via the control panel. This momentary push-button soft key is used to navigate the operational modes available through the control panel. This function is menu-driven.

1.5.4 7-Segment alphanumeric display

The 7-Segment alphanumeric display feeds back information from the Model 3100 to the user via the control panel. The primary purpose of the 7-segment display is to show the oxygen concentration readout. It is also used for feedback of operational status, fault codes, and other information necessary to perform system setup and maintenance.

1.5.5 RUN indicator LED

The purpose of the RUN indicator LED is to inform the user via the control panel that the Model 3100 is measuring the concentration of the sample gas and updating the display and outputs accordingly (with no alarm or fault conditions present).

1.5.6 Alarm-1 indicator LED

The purpose of the Alarm-1 indicator LED is to inform the user via the control panel that the measured oxygen concentration has exceeded the alarm-1 threshold (Alarm-1 and its associated relay are in active mode).

1.5.7 Alarm-2 indicator LED

The purpose of the Alarm-2 indicator LED is to inform the user via the control panel that the measured oxygen concentration has exceeded the alarm-2 threshold (Alarm-2 and its associated relay are in active mode).

1.5.8 Fault indicator LED

The purpose of the Fault indicator LED is to inform the user via the control panel that at least one system fault is active. Note that when the fault indicator LED is active the fault relay will also be active.

2 System installation and start-up

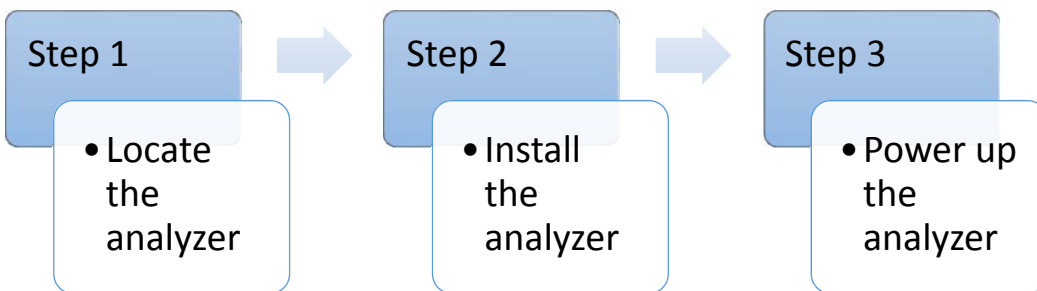

Fig. 7, installation and start-up

2.1 Installing the analyzer

2.1.1 Step 1 – Locate the Model 3100 analyzer

- ▶ Select a suitable location for mounting the analyzer where the digital display and status LED's will be easy to read and the interface buttons on the display panel will be easy to access
- ▶ Cut/drill the mounting panel to the specifications shown in Figure 8
- ▶ Clearance holes for the #8-32 threaded mounting studs do not need to be tapped. Hex nuts are included for securing the unit to a panel
- ▶ Trim all burrs or sharp edges in the cut-out or mounting-holes to prevent damage to the gasket
- ▶ Slide the analyzer unit into the cut-out, rear-chassis first, and seat the control panel gasket on the mounting surface. The gasket on the analyzer control panel ensures a watertight seal around the control panel cut-out.
- ▶ Secure the threaded mounting studs with the supplied hex-nuts and studded lock-washers. The analyzer control panel is suitable for NEMA Type 4, IP20 environments when properly installed. The rear electronics chassis is suitable for NEMA Type 1, IP 20 environments.
- ▶ Ensure the analyzer unit is mounted in an area of free airflow to prevent the chassis from exceeding the operating temperature specifications.
- ▶ Locate the unit away from hot surfaces
- ▶ Allow sufficient distance from adjacent surfaces to prevent blockage of the ventilation holes in the chassis.
- ▶ Allow for sufficient free airflow to prevent the chassis from exceeding the operating temperature specifications (max. ambient temperature of 40°C). Choose an area with a constant source of ambient air around the unit containing 20.9% oxygen. Higher or lower levels of oxygen concentration in the atmosphere around the unit will affect system accuracy.
- ▶ Do not subject the unit to mechanical impact, continuous mechanical vibration, or electrical shock
- ▶ Do not expose the unit to water, adverse temperatures, or flammable and corrosive gases

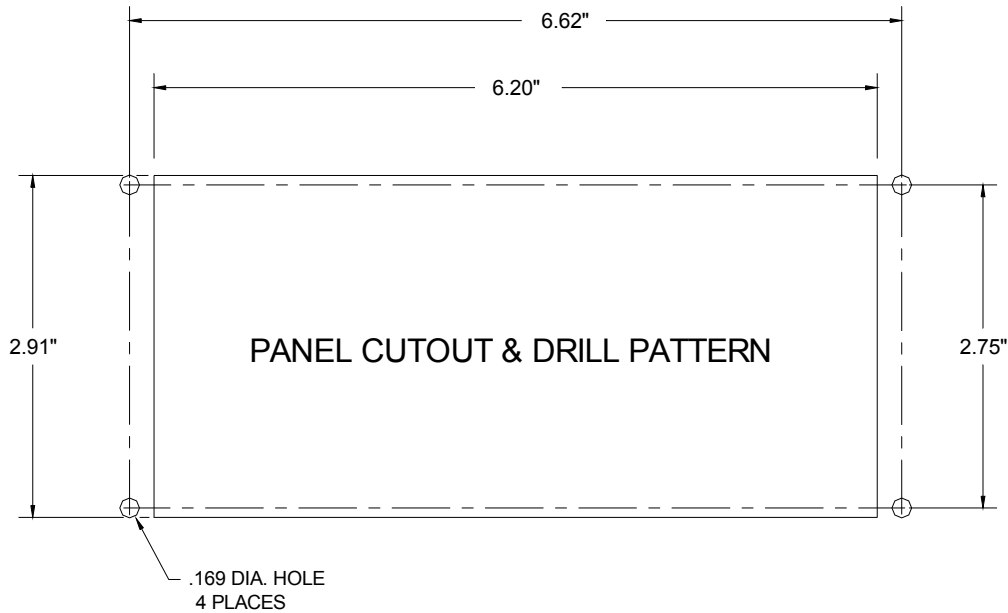

Fig. 8, Mounting panel cut-out

2.1.2 Step 2 – Install the remote sensor module (RSM)

Secure the unit to the mounting surface using the mounting holes in the base plate. For detailed instructions on RSM installation, please refer to the separate RSM instruction manual.

2.1.3 Step 3 – Install the analyzer

WARNING Electrical connections on the rear of the Model 3100 Oxygen analyzer may have hazardous voltages present once power has been applied to the unit. High voltages may remain present for a short time even after power has been disconnected from the analyzer. Take care in observing standard electrical practices when making electrical connections to the Model 3100 Oxygen analyzer.

DANGER: The model 3100 analyzer is not rated intrinsically safe or explosion proof. Be certain that no flammable gases are present in the area where the Model 3100 analyzer will be installed.

CAUTION: The model 3100 housing is not rated waterproof. Do not mount the analyzer or the sensor in an area where it may contact water or other liquid elements.

WARNING Be certain that all power is OFF to the analyzer and associated wiring (cables) before attempting installation. DO NOT WORK WITH LIVE WIRES! Do not leave any exposed wire at the terminal blocks. Before applying power, ensure terminal blocks are fully inserted into the mating connector at the analyzer.

A label depicting the terminal block arrangement (see Figure 9) is affixed to the top of the chassis for easy reference during installation and maintenance (208 VAC label is shown for reference only). The terminal blocks feature screwed terminals. The terminal blocks are also removable for ease of wiring or removal of the analyzer module).

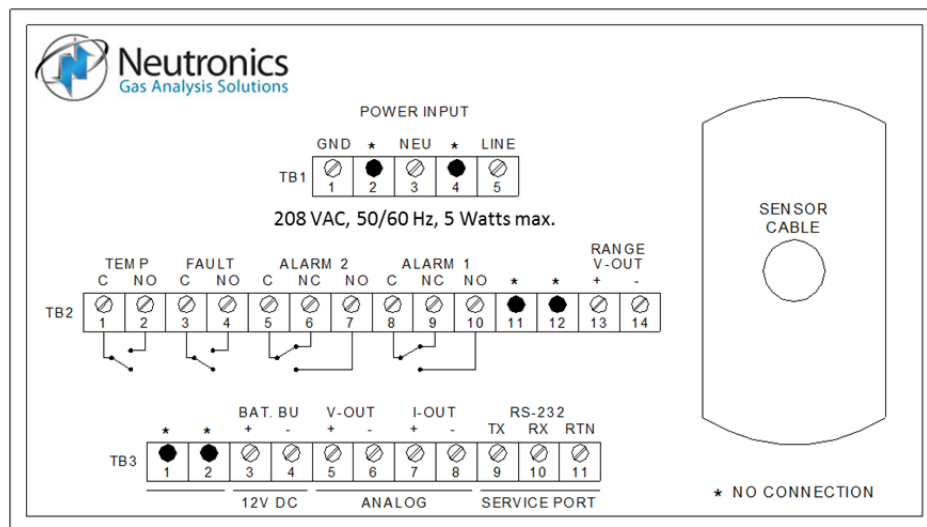

Fig. 9, Label on top of analyzer chassis

2.1.3.1 Remote sensor module input

All connections to the Remote Sensor Module (RSM) are made by connecting the supplied interface cable between the analyzer and the RSM. Plug the cable connectors into the mating receptacles on the analyzer chassis and RSM.

2.1.3.2 Alarm-1 relay output

Connections from the Alarm-1 relay contacts to the user's process control equipment are made at terminal block TB2 on the rear of the analyzer chassis (see Figure 10). The oxygen alarm relay contacts are voltage-free Form C relay contacts, SPDT, 5A @ 250 VAC, 5A @ 30 VDC. Connect the terminal pins in accordance with the schematic shown on the terminal ID label on the top of the analyzer chassis.

2.1.3.3 Alarm-2 relay output

Connections from the Alarm-2 relay contacts to the user's process control equipment are made at terminal block TB2 on the rear of the analyzer chassis. The oxygen alarm relay contacts are voltage-free Form C relay contacts, SPDT, 5A @ 250 VAC, 5A @ 30 VDC. Connect the terminal pins in accordance with the schematic shown on the terminal ID label on the top of the analyzer chassis.

2.1.3.4 Fault relay output

Connections from the Fault relay contacts to the user's process control equipment are made at terminal block TB2 on the rear of the analyzer chassis. The fault relay contacts are voltage-free Form B relay contacts, SPST, 5A @ 250 VAC, 5A @ 30 VDC. Connect the terminal pins in accordance with the schematic shown on the terminal ID label on the top of the analyzer chassis.

2.1.3.5 Heater OK relay output

Connections from the Heater OK relay contacts to the user's process control equipment are made at terminal block TB2 on the rear of the analyzer chassis. The heater OK relay contacts are voltage-free Form B relay contacts, SPST, 5A @ 250 VAC, 5A @ 30 VDC. Connect the terminal pins in accordance with the schematic shown on the terminal ID label on the top of the analyzer chassis.

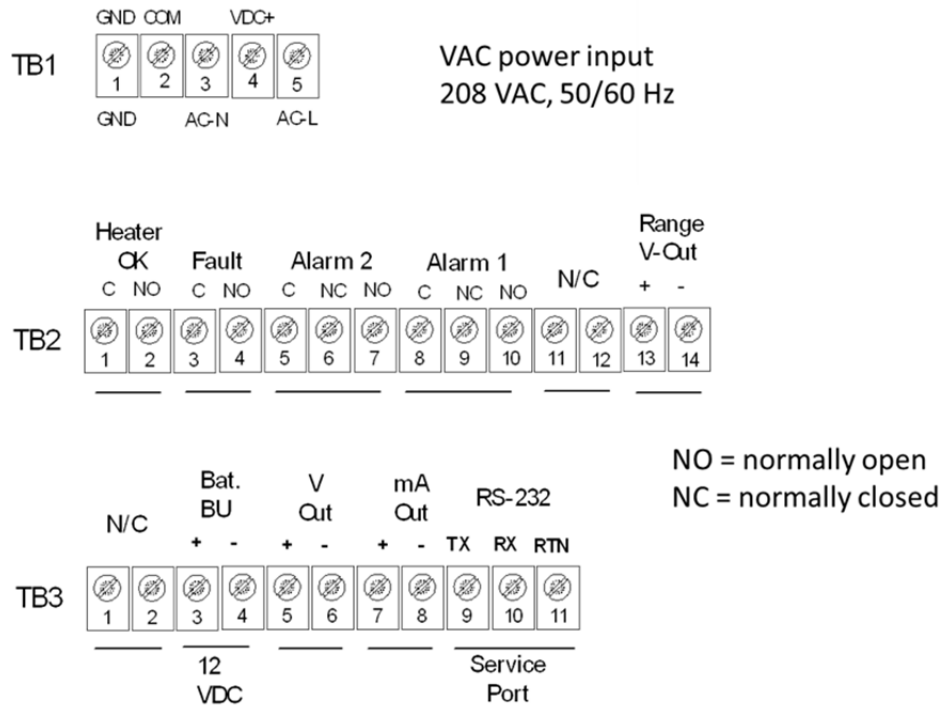

Fig. 10, Analyzer electrical connections

2.1.3.6 Range ID output

Connections from the Range ID output to the user’s auxiliary equipment are made at terminal block TB2 on the rear of the analyzer chassis. Connect the terminal pins in accordance with the schematic shown on the terminal ID label on the top of the analyzer chassis.

Use 20-AWG, 2-conductor, stranded-wire, twisted pairs for the connections. It is not necessary to use shielded cable for the Range ID output, with or without electrical barriers. If shielded cable is used, it should be drained to dc ground at the auxiliary equipment.

2.1.3.7 Analog voltage output

Connections from the analog voltage output to the user’s auxiliary equipment are made at terminal block TB3 on the rear of the analyzer chassis (see Figure 10). Connect the terminal pins in accordance with the schematic shown on the terminal ID label on the top of the analyzer chassis.

Use 20-AWG, 2-conductor, stranded-wire, twisted pairs for the connections. It is not necessary to use shielded cable for the Analog voltage output, with or without electrical barriers. If shielded cable is used, it should be drained to dc ground at the auxiliary equipment.

2.1.3.8 Analog current output

Connections from the analog current output to the user’s auxiliary equipment are made at terminal block TB3 on the rear of the analyzer chassis. The analog current output is a negative ground, non-isolated 0-20mA, or 4-20 mA current loop. 12 VDC power is supplied internally by the Model 3100 analyzer.

Maximum electrical loading is 250 Ohms. Connect the terminal pins in accordance with the schematic shown on the terminal ID label on the top of the analyzer chassis.

Use 20-AWG, 2-conductor, stranded-wire, twisted pairs for the connections. It is not necessary to use shielded cable for the Analog current output, with or without electrical barriers. If shielded cable is used, it should be drained to dc ground at the auxiliary equipment.

2.1.3.9 Battery backup

12-volt DC battery backup terminals are provided at terminal block TB3 on the rear of the analyzer chassis. These terminals may be connected to a fixed 12 VDC power source to act as a backup in case mains power has been lost. The circuit will detect loss of the mains power and the VDC battery backup will maintain power to the system.

Connection to the battery backup is not required for normal operation of the analyzer. Connect the terminal pins in accordance with the schematic shown on the terminal ID label on the top of the analyzer chassis.

2.1.3.10 RS-232 service port

Connections from the Range ID output to the user's auxiliary equipment are made at terminal block TB3 on the rear of the analyzer chassis. Connect the terminal pins in accordance with the schematic shown on the terminal ID label on the top of the analyzer chassis.

For interfacing with any standard PC computer via the serial port, use 20-AWG 3-conductor shielded, stranded-wire, jacketed cable -- terminated on one end with a female DB9 connector (see Figure 11). The shielding should be drained to dc ground at the computer.

Signal designation (analyzer)	Analyzer TB2 connection	Signal designation (computer)	Computer DB9 serial port connection
RX	Pin 9	TX	Pin 2
TX	Pin 10	RX	Pin 3
RTN	Pin 11	RTN	Pin 5

Fig. 11, Analyzer electrical connections

2.1.3.11 Mains power

Connections for Mains Power input are made at terminal block TB1 on the rear of the analyzer chassis. Connect the terminal pins in accordance with the schematic shown on the terminal ID label on the top of the analyzer chassis.

For VAC versions, use minimum 16-AWG 3-conductor, stranded-wire, for the connections. Supply single-phase 110/208 \pm 10% VAC, 50/60 Hz to the unit. For VDC versions, use 18-AWG, 3-conductor, stranded-wire, for the connections. Supply 12/24 VDC to the unit.

2.2 Step 3 – Start up and commissioning

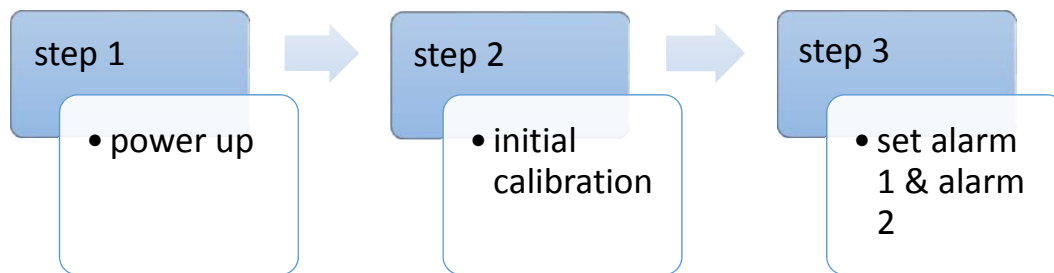

Fig. 12, Start up and commissioning

2.2.1 Power up check list

The Model 3100 is shipped ready to use. Factory default configuration settings are listed in Appendix C. Review the factory default configuration settings before commissioning your system. If you choose to change any of the factory default settings, refer to sections 4.1.1 and 4.1.2.

REMINDER: Always start up the unit with a sample inlet pressure of 6 psig or less. Exposing the sample pump to operating pressures higher than 6 psig may damage the unit. Verify the following conditions:

- No flammable vapors are present in the area
- No exposure to rain, dripping water, or hose down
- Wiring correctly installed – interface cable connected
- Plumbing connections on the RSM are gas-tight
- Ambient temperature is below 40° C (104° F)

2.2.2 Step 1 -- Power up the unit

When the Model 3100 is powered-up, it will go through a 5-second self-test. The 7-segment alphanumeric display will show “8.8.8.8.”, then XXXX (software build), and then the power supply voltage setting. The RUN, Alarm-1, Alarm-2, and Fault LED indicators will go through a display test sequence (lamp test). Upon completion, the analyzer will enable the RSM warm-up.

The RSM warm-up takes approximately eight minutes. The digital display will alternately indicate ‘nr’ (system not ready) and the temperature of the sensor heater until warm-up is complete.

After the warm-up period is completed, the Model 3100 will check the current sensor reading and update the digital display and status LED’s. When configured for auto-ranging, the Model 3100 analyzer will automatically display units in parts per million or in percent oxygen, according to the sensor output. When the analyzer is in percent range oxygen measurement, the display flashes the concentration in *bright then dim* illumination. When the analyzer is in parts-per-million range oxygen measurement, the display shows the concentration illuminated *steadily bright*.

Once the analyzer reading has stabilized (approx. 20 minutes for thermal equilibrium), the user may apply an instrument air source to the sample inlet port of the RSM (see RSM equipment manual) to check the unit. Allow the reading to stabilize. It should take about 30 seconds for the gas to sweep out the sample lines. Verify the 7-segment alphanumeric display shows 20.9 % oxygen.

2.2.3 Step 2 -- Calibrate the unit

All units are calibrated at the factory prior to shipment. During commissioning, a reference air calibration is required to adjust for any differences in elevation or atmospheric pressure at the installation site. Refer to section 3.4.1 for detailed calibration instructions.

2.2.4 Step 3 –Set Alarm-1 and Alarm-2

After the unit has been calibrated on a known gas source, set the alarm points according to process control requirements. Refer to Appendix C for factory settings.

2.2.4.1 Set Alarm-1

For process control applications, Alarm-1 is typically used as the “primary” oxygen-level alarm. It is set to the highest or lowest level of allowable oxygen concentration in your process, according to the application. Refer to Appendix C for factory settings. Refer to section 3.2.2 for information about setting the Alarm-1 level.

2.2.4.2 Set Alarm-2

For process control applications, Alarm-2 is typically used as the “secondary”, or “warning” oxygen-level alarm. It is set just below the highest or just above the lowest level of allowable oxygen concentration in your process, according to the application. Refer to section 3.2.3 for information about setting the alarm-2 level.

The Model 3100 should now be ready for commissioning. Neutronics Inc. offers commissioning and Factory Acceptance Testing services by our certified technicians. You may contact the Neutronics factory toll-free at (800) 378-2287 or (610) 524-8800. Ask one of our service technicians to schedule a service appointment.

3 Operation

3.1 Overview

The Model 3100 has two types of operational modes – **User-type**, and **System-type**. User modes are initiated and controlled by the user and used to setup and maintain the analyzer. The User modes are: Calibration, Set/view Alarm-1, Set/view Alarm-2, View Active Faults, and Setup. Operating modes are accessed automatically by the analyzer during normal operation, according to its programming and configuration parameters. The operating modes are: Self-Test & Warm-up, Run, Alarm-1 Active, Alarm-2 Active, and Fault Active (see Figure 13).

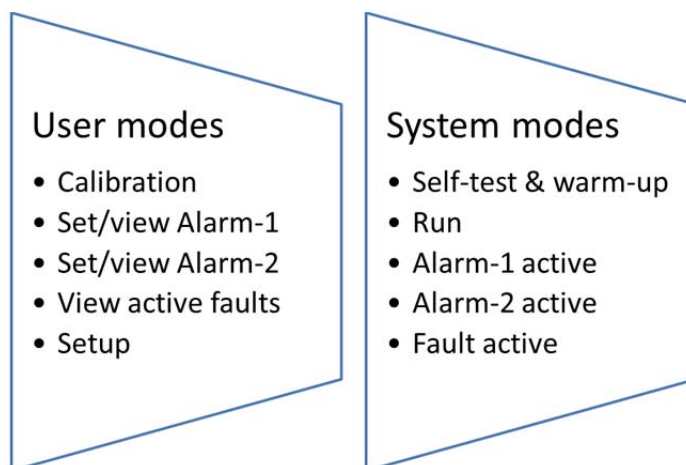

Fig. 13, Operational modes

3.2 User modes

At any time, the user can initiate any of the user modes either from the control panel or through the service port. Control panel access of the Calibration, Set/view Alarm-1, Set/view Alarm-2 and View Active Faults modes will be covered in this section. System setup mode and user access via the service port will be covered in section 4.1.

The user modes -- Calibration, Set/view Alarm-1, Set/view Alarm-2 and View Active Faults -- are accessed serially via the control panel, by repeatedly pressing and releasing the “MODE” key. When a user mode is accessed via the control panel, the Model 3100 aborts any system mode active and holds the state of Alarm-1 and Alarm-2 outputs until the user returns the unit to “RUN” mode.

Note: All analog electrical outputs from the Model 3100 analyzer follow the oxygen readout displayed on the 7-segment LED display during the calibrate, set/view alarm-1, and set/view alarm-2 modes.

3.2.1 Calibration

Calibration mode allows the oxygen sensor and analyzer to be aligned to gases of known oxygen concentration for the most accurate on-line readings. Gas calibration is required at system commissioning. The Model 3100 uses a non-depleting solid-state oxygen sensor. During the normal service life of the sensor (5-7 years), no additional calibration is required for performance compliant with system specifications,

Note: To ensure the highest system reliability, it is recommended that the display reading be validated against a known gas source annually or in accordance with operating guidelines (see the periodic maintenance schedule in section 4.2). Refer to section 4.2.2 for the display reading validation procedure.

3.2.1.1 Calibration – Introduction

For best application-driven accuracy, the Model 3100 is capable of a two-point calibration – explained in this manual as **Reference** calibration, and **Span** calibration. Reference calibration is always performed using ambient air with an oxygen concentration of 20.9%. Span calibration uses a gas that profiles the in-service oxygen measurement range. When gases are selected properly, the analyzer automatically identifies them as reference or span calibration gases during the calibration sequence (and applies any user-entered correction factors).

3.2.1.2 Step 1 – Select the calibration gases

The following calibration gas sources can be used to calibrate the Model 3100:

Reference Calibration Gas: Use Instrument Grade compressed air (Dew-point < 35°; particulates < 3-micron; condensable hydrocarbons < 1-part-per-million) or Certified Standard grade bottled gas at 20.9 % oxygen concentration.

Span Calibration Gas: Use Certified Standard Grade bottled calibration gas – 1 PPM to 17% oxygen concentration or 25% to 100% oxygen concentration. Select a gas between 80% and 120% of the expected maximum usable on-line measurement and within the configured range of the Model 3100.

3.2.1.3 Step 2 – Remove the sensor from online service

Disconnect the Remote Sensor Module (RSM) from the measured process. Refer to the RSM manual for detailed instructions.

Warning: Before opening any part of the sampling system to air, make sure that the sampling lines are not pressurized and clear of any gas that may create a personnel or environmental hazard.

3.2.1.4 Step 3 – Apply reference calibration gas to the oxygen sensor

Attach the RSM to the selected Reference Calibration Gas with oxygen concentration of 20.9%. Refer to the RSM manual for detailed instructions on connecting and applying calibration gas to the unit. Flow calibration gas to the sensor until the analyzer display has stabilized. This allows the calibration gas to sweep out the sample lines.

 **WARNING** Never apply an unregulated gas supply to the oxygen sensor. High or uncontrolled pressures may damage the oxygen sensor or sampling system components.

3.2.1.5 Step 4 – Calibrate the analyzer with reference gas

After applying a regulated stream of calibration gas to the sensor, press and release the “MODE” key once. The 7-segment alphanumeric display will show “CAL”, then an oxygen concentration value. Adjust the displayed oxygen concentration value to read 20.9% oxygen by pressing the “UP” or “DOWN” arrow key as required. Press and release the “MODE” key four times to return to “RUN” mode.

3.2.1.6 Step-5 – Apply span calibration gas to the oxygen sensor

Attach the RSM to the selected Span Calibration Gas. Refer to the RSM manual for detailed instructions on connecting and applying calibration gas to the unit. Flow calibration gas to the sensor until the analyzer display has stabilized. This allows the calibration gas to sweep out the sample lines.

Note: The Span calibration gas must have an oxygen concentration outside of the range 18% to 24% for the analyzer to operate properly. If the in-service oxygen sample range is within the 18% to 24% window under normal operating conditions, Span gas calibration is not necessary.

3.2.1.7 Step-5 – Calibrate the analyzer with span gas

After applying a regulated stream of calibration gas to the sensor, press and release the “MODE” key once. The 7-segment alphanumeric display will show “CAL”, then an oxygen concentration value. Adjust the displayed oxygen concentration to read the applied calibration gas oxygen concentration by pressing the “UP” or “DOWN” arrow key as required. Press and release the “MODE” key four times to return to RUN mode.

3.2.1.8 Step-6 – Return the oxygen sensor to on-line service

Remove calibration gas from the Remote Sensor Module, and reconnect to the measured process. Refer to the Remote Sensor Module user manual for details on applying sample gas to that apparatus. Be sure to flow sample gas to the sensor until the analyzer display has stabilized to allow time to sweep the sample lines clear of calibration gas.

3.2.2 Set/view ALARM-1 mode

To enter Set Alarm-1 mode during “RUN” mode -- using the keypad, scroll through the user mode menu by momentarily pressing the “MODE” key two (2) times -- until the 7-segment alphanumeric display reads “AL1” (set alarm-1 level) and the “ALM1” indicator LED flashes. The display will momentarily show “AL1” and then the current Alarm-1 threshold level (an O₂ concentration). Use the “UP” and “DOWN” keys to adjust the Alarm-1 setpoint level. Changed settings are automatically saved when the “MODE” key is pressed to enter the next mode.

3.2.3 Set/view ALARM-2 mode

To enter Set Alarm-2 mode during “RUN” mode -- using the keypad, scroll through the user mode menu by momentarily pressing the “MODE” key three (3) times -- until the 7-segment alphanumeric display reads “AL2” (set alarm-2 level) and the “ALM2” indicator LED flashes. The display will momentarily show “AL2” and then the current Alarm-2 threshold level (an O₂ concentration). Use the “UP” and “DOWN” keys to adjust the Alarm-2 setpoint level. Changed settings are automatically saved when the “MODE” key is pressed to enter the next mode.

3.2.4 View active faults mode

To enter View Active Faults mode during RUN mode -- using the keypad, scroll through the user mode menu by momentarily pressing the “MODE” key four (4) times -- until the 7-segment alphanumeric display reads “FL” and the “FAULT” indicator LED flashes. The display will momentarily show “FL” and then the

highest priority active system fault. Press and release the “UP” or “DOWN” key to scroll through all active system faults. Refer to section 4.3.1 for a complete fault code listing and troubleshooting guide. To exit, press and release the “MODE” key.

3.2.5 Return to RUN mode

To exit and go back to “RUN” mode from any user mode -- using the keypad; scroll through the control panel user mode menu by pressing repeatedly the “MODE” key -- until the 7-segment alphanumeric display shows “RUN”. The display will then show an oxygen concentration. The ALM1, ALM2, and FAULT LED’s will flash for 120 seconds to indicate that the analyzer is stabilizing. This is to allow time to sweep the sample lines with sample gas before returning the unit to on-line service. During the stabilization period, Alarm-1 and Alarm-2 relays remain inactive, holding to their last state before the control panel user mode menu was accessed.

3.3 System modes

The Model 3100 has five System modes – Self-Test & Warm-up, RUN, Alarm-1 Active, Alarm-2 Active, or Fault Active. Self-test & warm-up modes are fixed routines that are initiated upon each start-up. The remaining system modes, provided no valid manual input is received at the control panel or service port, are initiated automatically by the analyzer according to setup parameters entered by the user in Setup mode. Values are compared against monitored inputs and other monitored system hardware in real time.

3.3.1 Self-test & warm-up mode

When the Model 3100 is started up, it enters into Self-Test & Warm-up mode automatically, followed by a sensor heater warm-up period (see section 2.2.1). When the sensor heater reaches operating temperature, the analyzer aborts the warm-up routine, checks the current sensor signal, updates the 7-segment LED display, status LED’s, and Analog outputs, then enters into the appropriate system mode according to its programmed parameters.

3.3.2 RUN mode

The Model 3100 initiates “RUN” mode when it is continuously measuring the oxygen concentration of the sample gas. The display and outputs are updated automatically until valid user input is detected. An illuminated or flashing “RUN” LED indicates that the instrument is on-line and that the system is operating properly.

When the measured process oxygen concentration falls outside of programmed alarm parameters or the system experiences a fault condition, the Model 3100 analyzer enters into Alarm-1 Active, Alarm-2 Active, and/or Fault Active mode accordingly. The system does not abort “RUN” mode -- the “RUN” indicator LED stays lit. The appropriate indicator LED will illuminate in addition to the “RUN” indicator LED.

When programmed alarm setpoints and/or fault conditions are cleared, the Model 3100 analyzer aborts Alarm-1 Active, Alarm-2 Active, and/or Fault Active mode accordingly. The system does not abort “RUN” mode, and the “RUN” indicator LED stays lit. Indicator LED’s mapped to aborted modes will turn off.

When the Model 3100 analyzer detects valid user-input, it enters into one of the user modes – Calibration, Set/view Alarm-1, Set/view Alarm-2, View Active Faults, or User Setup. The analyzer aborts “RUN” mode and holds the state of Alarm-1 and Alarm-2 relay outputs. The “RUN” indicator LED will turn off, except when the unit is in Calibrate mode (“RUN” indicator will flash on and off).

When the user manually aborts all user modes by returning the system to “RUN” mode (or when no valid user input is detected for 120-seconds), the Model 3100 checks the current sensor signal, updates the 7-segment LED display, status LED’s, and analog outputs, and then enters into the appropriate system

mode according to its programmed parameters. Alarm-1, and Alarm-2 relay outputs are released and the “RUN” indicator LED is turned on.

3.3.3 ALARM-1 Active mode

The Model 3100 initiates Alarm-1 Active mode when it has detected that the measured oxygen concentration has exceeded the set threshold value of Alarm-1 (section 3.2.2). The “ALM1” indicator LED will turn on and the “RUN” indicator LED will remain lit. The Alarm-1 relays will change state according to the analyzer configuration (Appendix C, Factory Setup). The alarm status will be cleared automatically when the measured oxygen concentration is within the set threshold value of Alarm-1. The “ALM1” indicator LED will turn off and the Alarm-1 relays will return to their non-active state according to the analyzer configuration. The Alarm-1 Active mode is overridden by manual access to the user mode menu.

3.3.4 ALARM-2 Active mode

The Model 3100 initiates Alarm-2 Active mode when it has detected that the measured oxygen concentration has exceeded the set threshold value of Alarm-2 (section 3.2.3). The “ALM2” indicator LED will turn on and the “RUN” indicator LED will remain lit. The Alarm-2 relays will change state according to the analyzer configuration (Appendix C, Factory Setup). The alarm status will be cleared automatically when the measured oxygen concentration is within the set threshold value of Alarm-2. The “ALM2” indicator LED will turn off and the Alarm-2 relays will return to their non-active state according to the analyzer configuration. The Alarm-2 Active mode is overridden by manual access to the user mode menu.

3.3.5 FAULT Active mode

The Model 3100 initiates Fault Active mode when it has detected that one or more Fault conditions have been satisfied (see section 4.3.1). The “FAULT” indicator LED will turn on and the Fault relays will change state. The Fault status will be cleared automatically when no Fault conditions have been satisfied. The “FAULT” indicator LED will turn off and the Fault relays will return to their non-active state. The user may view active faults at any time from the control panel (see section 3.2.4).

4 Setup, maintenance, and troubleshooting

4.1 System setup

The Model 3100 is shipped with the system configuration installed and tested, ready for installation and operation. The user has the option to change the system configuration to suit the application of the analyzer. Some setup parameters can be changed by the user via the control panel keypad. All configuration parameters can be changed by the user via the Service Port.

Important: Before changing any of the Model 3100 settings, refer to Appendix C – Factory Setup for reference. If the user has any questions before proceeding with changing analyzer settings, please contact the Neutronics Service Department for assistance.

4.1.1 System setup via control panel keypad

The control panel User Setup menu may be accessed from the Model 3100 control panel by pressing and holding the “MODE” key for at least 6-seconds -- until the 7-segment alphanumeric display shows “---.” This indicates that the analyzer has accessed setup mode. Release the “MODE” key to activate setup mode. Once in setup mode, the user can access adjustable parameters sequentially by continuing to press and release the “MODE” key to scroll through the setup menu.

When you reach the mode that you wish to change, use the “UP” and “DOWN” keys to adjust the displayed setting. The modes are numerically identified by the number on the left side of the display. The current mode setting is identified by the number on the right side of the display (see Figure 14). The new settings are automatically saved when the user advances to the next mode by pressing and releasing the “MODE” key. The user may exit the Setup menu at any time by pressing simultaneously the “UP” and “DOWN” keys (see Appendix D, Control panel hot-key functions).

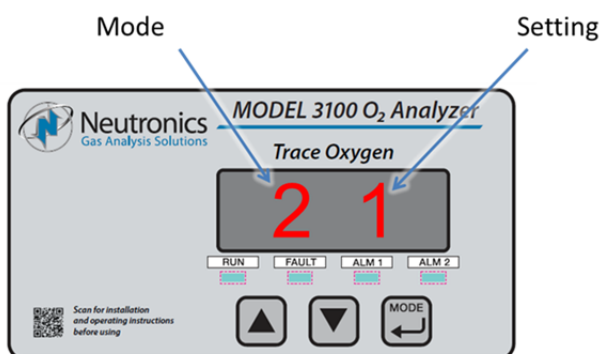

Fig. 14, System setup using the control panel keypad

4.1.1.1 User Setup Mode A: Display range select

Setup Mode A allows the user to map the display and electrical output range scale of the Model 3100 to suit the application (see Appendix E – Range / Output Chart). Valid settings are listed in Figure 15.

Mode	Valid setting
A	1 (0-10 ppm)
A	2 (0-100 ppm)
A	3 (0-1,000 ppm)
A	4 (0-10,000 ppm)
A	5 (0-10%)
A	6 (0-100%)
A	8 (auto-range)

Fig. 15, Valid settings for setup Mode A

4.1.1.2 User Setup Mode 1: Alarm-1 relays (descending or ascending)

Setup Mode 1 allows the user to set the Alarm-1 relay action to descending (the relay is set to its active state when the oxygen level is below the Alarm-1 level set point) or ascending (the relay is set to its active state when the oxygen level is above the Alarm-1 level set point). Valid settings are listed in Figure 16.

Mode	Valid setting
1	0 (descending)
1	1 (ascending)

Fig. 16, Valid settings for setup Mode 1

4.1.1.3 User Setup Mode 2: Alarm-2 relays (descending or ascending)

Setup Mode 2 allows the user to set the Alarm-2 relay action to descending (the relay is set to its active state when the oxygen level is below the Alarm-1 level set point) or ascending (the relay is set to its active state when the oxygen level is above the Alarm-1 level set point). Valid settings are listed in Figure 17.

Mode	Valid setting
1	0 (descending)
1	1 (ascending)

Fig. 17, Valid settings for setup Mode 2

4.1.1.4 User Setup Mode 3: Analog voltage output setting

Setup Mode 3 allows the user to set the Analog Output Voltage full scale to 1, 5, or 10 volts. Note that the software settings must match the RA and RB jumper settings on the Main CPU PCB (section 4.1.3). Valid settings are listed in Figure 18.

Mode	Valid setting
3	0 (0-5 V)
3	1 (0-10 V)
3	2 (0-1 V)

Fig. 18, Valid settings for setup Mode 3

4.1.1.5 User Setup Mode 4: Serial output format

Setup Mode 4 allows the user to set the RS-232 communications timed output format. Valid settings are listed in Figure 19.

Mode	Valid setting
4	0 (output on request)
4	1 (human readable)
4	2 (machine code)
4	3 (machine code with checksum)
4	4 (tab delimited)

Fig. 19, Valid settings for setup Mode 4

4.1.1.6 User Setup Mode 7: Set low-end calibration range

Setup Mode 7 is the zero calibration range that is set by the factory (see Figure 20). It should not be adjusted by the user. If the user changes the zero calibration range, the Model 3100 will not operate properly.

Mode	Valid setting
7	9 (18 to 24% O ₂)

Fig. 20, Factory setting for setup Mode 7

4.1.1.7 User Setup F: Alarm-1 and Alarm-2 relays (fail-safe or non-fail-safe action)

Setup Mode F allows the user to set the Alarm-1 and Alarm-2 relays to either fail-safe action (relay coils not powered in active alarm state) or non-fail-safe (relay coils powered in active alarm state). Valid settings are listed in Figure 21.

Mode	Valid setting
F	0 (non-fail-safe)
F	1 (fail-safe)

Fig. 21, Valid settings for setup Mode F

4.1.1.8 User Setup B: RS-232 baud rate

Setup Mode B allows the user to set the RS-232 communications baud rate. Valid settings are listed in Figure 22.

Mode	Valid setting
B	1 (300 bps)
B	2 (1200 bps)
B	3 (2400 bps)
B	4 (4800 bps)
B	5 (9600 bps)
B	6 (19200 bps)
B	7 (38400 bps)

Fig. 22, Valid settings for setup Mode F

4.1.1.9 User Setup C: Clean mode enable

Setup Mode C allows the user to enable a sensor self-cleaning cycle if the oxygen sensor has been exposed to chemicals or gases that may be affecting its performance. Before enabling clean mode, the RSM should be removed from on-line service. The sampling system should be purged with either nitrogen or Instrument Grade Compressed Air (Refer to the Remote Sensor Module equipment manual).

If enabled in the control panel user setup menu, Sensor Clean mode will initiate when the analyzer is returned to "RUN" mode. Scroll through the control panel setup menu by pressing and releasing the "MODE" key repeatedly until the 7-segment alphanumeric display shows "RUN". The display will then alternately show "CLE" and the temperature of the sensor heater in degrees centigrade (Refer to the RSM instruction manual). After the sensor heater reaches the cleaning temperature, the sensor clean routine should be left active for 24-hours.

Sensor clean mode will abort automatically, two minutes after the sensor heater reaches the cleaning temperature, if no additional user input is detected. To abort sensor clean mode manually, press the "UP" and "DOWN" keys on the analyzer control panel simultaneously. To verify that the analyzer has aborted sensor clean, return to setup mode C. The display should show "C__0". Valid settings are listed in Figure 23.

Mode	Valid setting
C	0 (disable sensor clean mode)
C	1 (enable sensor clean mode)

Fig. 23, Valid settings for setup Mode C

4.1.1.10 User Setup E: Remote sensor module supply voltage

Setup Mode E allows the user to set the VAC supply voltage to the RSM. Note that the software settings must match the VAC switch setting on the RSM module (refer to the RSM manual). Valid settings are listed in Figure 24.

Mode	Valid setting
E	0 (110 VAC)
E	1 (208 VAC)

Fig. 24, Valid settings for setup Mode E

4.1.1.11 User Setup 8: Factory setup restore

Setup Mode 8 allows the user to return the Model 3100 to its initial factory-commissioned settings. Always perform a gas calibration after restoring factory settings.

Mode	Valid setting
8	88 (activate factory setup restore)

Fig. 25, Valid setting for setup Mode 8

4.1.2 System setup via RS-232 service port

The Model 3100 analyzer features a Service Port, which is accessible for programming the system, monitoring the analyzer output, and determining active fault codes for troubleshooting. The Service Port has been designed for communication with devices capable of receiving and transmitting ASCII data packets over a standard RS-232 serial interface.

Access to the Serial Service Port may also be made through a terminal emulator program such as HyperTerminal (available in Microsoft Windows 95 or later).

4.1.2.1 RS-232 service port interfacing with HyperTerminal

Turn off your computer and remove power from the Model 3100. Complete the instructions for wiring and connecting the Model 3100 to a PC computer (see section 2.1.3.10). Apply power to the Model 3100 and then start up the PC computer.

On your PC computer, open HyperTerminal: Navigate from the Windows desktop – Select Start > Programs > Accessories > Communications > HyperTerminal

In HyperTerminal, create and configure a new connection – follow these prompts:

```
PROMPT > YOU ENTER
CONNECTION NAME > 3100
CONNECT TO COM1 (or other available COM port)
```

In HyperTerminal, select the correct COM port properties, to interface with the Model 3100:

```
PROPERTIES > YOU ENTER
BITS PER SECOND > 9600
DATA BITS > 8
```

PARITY > None

STOP BITS > 1

FLOW CONTROL > None

TERMINAL EMULATION > VT 100 * (*Not all versions of MS Windows prompt for this parameter)

Select "Apply" and "OK" as prompted. The HyperTerminal program will immediately begin communicating with the Model 3100, and the Model 3100 will commence sending data via ASCII code dump to the PC. The information from the analyzer will be sent in ASCII strings, at 1-second intervals. Data will be sent in the factory default "Human Readable" format.

4.1.2.2 Troubleshooting Your HyperTerminal interface

If serial communications with the Model 3100 fails, isolate the problem by performing the following tests:

Disconnect the RS-232 cable from the Model 3100 by removing the terminal block connector from TB3. Insert a jumper between pins 9 & 10 on the terminal block connector. Enter a few letters from the PC keyboard. The PC monitor should display the corresponding alpha-characters as they are typed. If the letters do not display on the monitor screen, there is a problem with the RS-232 cable, the PC serial COM port, or the HyperTerminal setup.

If the typed letters DO show on the monitor screen and serial communications with the Model 3100 still has not been established, then PC COM port pins 2 & 3 (3100 pins 9 & 10) may be reversed. Verify the cable wiring (section 2.1.3.10). If no transmitted data from the Model 3100 is seen on the monitor screen, call the Neutronics Service Department for further assistance.

4.1.2.3 RS-232 serial data access

There are three levels of access through the service port that can be used for interfacing with the Model 3100:

- 1) Standard Access: ASCII dump to a PC, printer, or DAQ -- provides basic operator access
- 2) Advanced Level-1 Access: Allows user setup and configuration -- such as alarms and data format
- 3) Advanced Level-2 Access: Allows access to vital control areas via password

4.1.2.4 Standard level access

Standard Level Access is the default level of access to the Model 3100 available to the user via a host computer or printer over a standard RS-232 serial interface. In Standard Level access, the user can make inquiries about oxygen concentration, sensor signal level, and other parameters for system servicing and troubleshooting.

When communications are established between the Model 3100 and a host computer, 2-way communication begins automatically in Standard Level access. Data is sent out through the analyzer RS-232 Service Port to the host terminal once-per-second, in the factory-default Human Readable format (see section 4.1.2.4.2). There are no commands necessary to begin viewing information transmitted by the Model 3100 in Standard Level access.

To request and view specific information via the RS-232 interface, type the desired command key selected from the Standard Access level command chart below (see Figure 26). It is not necessary to press "Enter."

Helpful Hint: For viewing convenience, before requesting specific information from the Model 3100, disable automatic 1-second updates from the Model 3100 and allow access of information by-request-only (see section 4.1.2.4.1). Type "SSERFMT=0", followed by the Return key. To return to automatic 1-second updates of data from the analyzer in Human Readable format (see section 4.1.2.4.2), type "SSERFMT=1", followed by the Return key.

Typed command	Description of queried function
A	Short software version
C	Analyzer model number
D	Sensor output in ppm O2
E	Sensor output in percent O2
F	Oven temperature
G	Sensor output in volts
H	Active fault codes
I	Active fault code descriptions
V	Long software version
@	Unit serial number

Fig. 26, Standard access level commands

There are several data formats of the ASCII data dump available (see Figure 27). They may be changed in Standard Level Access to suit the user's needs as follows:

Typed command	Description of queried function
SSERFMT=0	Disables RS-232 continuous periodic data-dump
SSERFMT=1	Enables RS-232 output in HUMAN READABLE format
SSERFMT=2	Enables RS-232 output in MACHINE format w/o Checksum
SSERFMT=3	Enables RS-232 output in MACHINE format w/Checksum
SSERFMT=4	Enables RS-232 output in TAB DELIMITED (Excel) format
SCALIBRATE=.XXXXXX	The user can send a calibration value in decimal format where 100% O2 = 1 (the number format entered must be 6-decimal places)

Fig. 27, Data formats

4.1.2.4.1 Disable RS 232 continuous output – SSERFMT=0

The factory default 1-second data-dump in Standard Level access can be disabled through the RS-232 interface in Standard Access level. While this setting is active, the user must request information by pressing the desired key according to the STANDARD ACCESS level commands chart.

4.1.2.4.2 Human Readable data format – SSERFMT=1

The factory default format is Human Readable and can be changed via the analyzer control panel, or through the RS-232 interface in Standard Level Access. Human Readable data is presented in dynamic columns (columns appear only when data is present). It is intended for most users, to aid in setup and maintenance of the unit. Column headings from left to right: Mode | O2 Concentration | Alarm-1 status | Alarm-1 status | list of Fault codes active.

4.1.2.4.3 Machine data format with NO Checksum

Machine format with NO checksum can be selected via the analyzer control panel, or through the RS-232 interface in Standard Access level. Machine format with NO checksum data is streamed in packets defined by start/stop transmit bits. The order of data in each packet is as follows: Start Transmit | O2 Concentration | Fault codes active | List of Fault Codes | Alarm-1 status | Alarm-1 status | End Transmit. For detailed information on data formats, please contact the Neutronics Service Department.

4.1.2.4.4 Machine data format WITH Checksum

Machine format with checksum can be selected via the analyzer control panel, or through the RS-232 interface in Standard Access level. Machine format with checksum data is streamed in packets defined by start/stop transmit bits. The order of data in each packet is as follows: Start Transmit | O2 Concentration | Fault codes active | List of Fault Codes | Alarm-1 status | Alarm-2 status | Checksum | End Transmit. For detailed information on data formats, please contact the Neutronics Service Department.

4.1.2.4.5 Tab delimited data format

Tab delimited format can be selected via the analyzer control panel, or through the RS-232 interface in Standard Access level. Tab delimited data is presented in static columns (the same number of columns is always transmitted in a complete data message). Column headings from left to right: Time since last re-boot tab | Mode tab | O2 Concentration tab | Alarm-1 status tab | Alarm-2 status tab | list of Fault codes active tab. For detailed information on data formats, please contact the Neutronics Service Department.

4.1.2.5 Advanced Level 1 access

Advanced Level-1 access is the computer-interfaced user Setup mode. Access to Advanced Level-1 can be accomplished on a PC by typing “setup” when viewing the Human Readable ASCII output. The User Setup menu will be displayed on the PC screen allowing access for changing the system setup (see Figure 28).

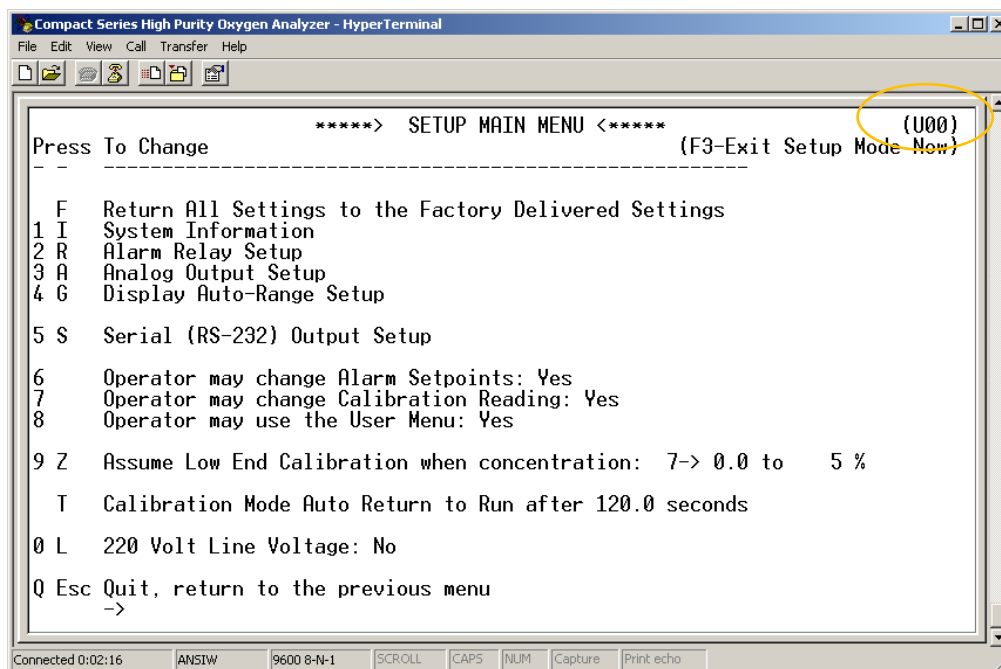

Fig. 28, Level-1 Access (Setup Mode menu)

4.1.2.6 Advanced Level-2 Access

Advanced Level-2 access is available to the user via a PC by use of a password. This level of access allows the manipulation of all code settings. Contact the Neutronics Inc. Service Department for support before attempting to use Advanced Level-2 access.

4.1.2.7 Setting up the Model 3100 – RS-232 User setup menu

The RS-232 User Setup menu U00 is the “Home” screen in Advanced Level-1 access (section 4.1.2.5), and provides access to all the parameters that may need to be adjusted by the user. The interactive menu is initiated by typing “setup” and pressing the “Enter” key on the RS-232 terminal (same as entering Advanced Level-1 access). To go back, use the <Esc> or “Q” key on the RS-232 terminal.

4.1.2.8 Return all settings to factory delivered settings

In case of severe corruption of calibration and setting information, this setting will allow the user to restore the Model 3100 analyzer to its “out-of-box” settings. The user may type “Y” at the prompt to initiate a restore, or “N” and the prompt to bypass a restore. This setting is accessed from the Setup Main Menu by typing “F” on the RS-232 Terminal. To go back, use the <Esc> or “Q” key on the RS-232 terminal.

4.1.2.9 System information display

The System Information Display U10 is a list of all the current settings for the Model 3100 analyzer. It is accessed from the Setup Main Menu by typing “1” or “I” on the RS-232 Terminal.

4.1.2.10 Alarm relay setup menu (U20)

The RS-232 Alarm/Relay Setup menu U20 (see Figure 29) provides access to all of the settings related to the Alarms, controls, and relays on the Model 3100 analyzer. It is accessed from the Setup Main Menu

by typing “2” or “R” on the RS-232 Terminal. To go back, use the <Esc> or “Q” key on the RS-232 terminal.

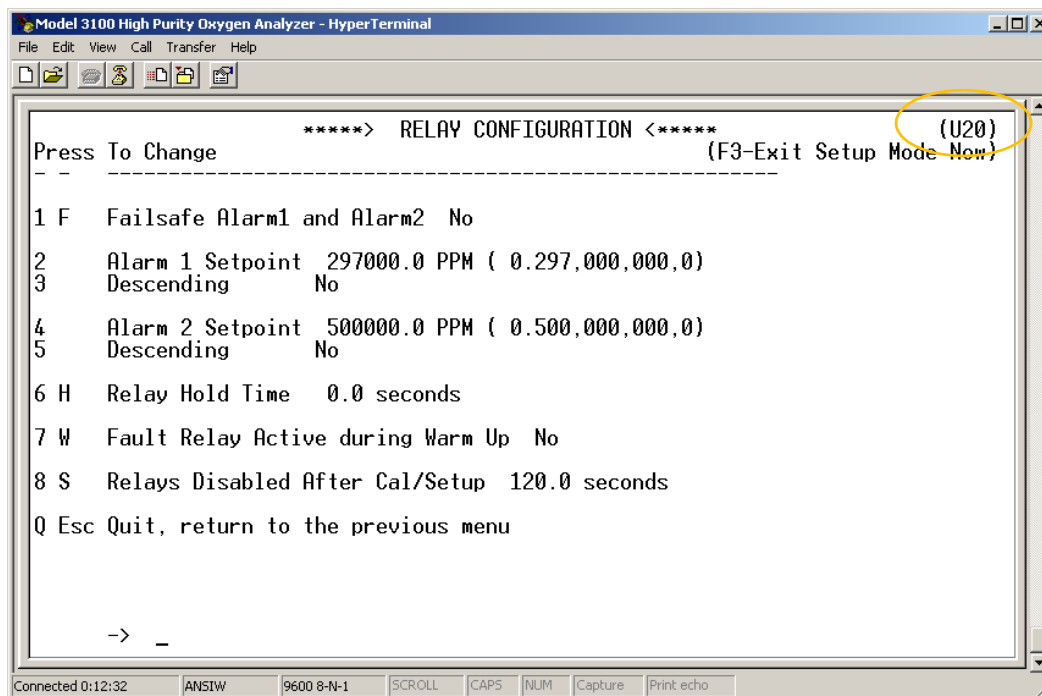

Fig. 29, Relay configuration menu

4.1.2.10.1 Alarm-1 and Alarm-2 relays fail-safe

This parameter allows the user to set the Alarm-1 and Alarm-2 relays to either fail-safe or non-fail-safe action. Failsafe action is defined as; relay coils are not powered (contacts are in normal position) in active alarm state. Non-fail-safe action is defined as; relay coils are powered (contacts are in non-normal position) in active alarm state. The Alarm-1 and Alarm-2 Relays Failsafe setting may be set to “YES” or “NO”. This setting is accessed from the Alarm and Relay Setup Menu by typing “1” or “F” on the RS-232 terminal.

4.1.2.10.2 Alarm-1 Level setting (setpoint)

This setting sets the threshold level for Alarm-1. Depending on whether or not it is set to ascending or descending, Alarm-1 becomes active when the oxygen concentration is above or below this threshold level. The Alarm-1 setpoint may be set anywhere from 0 PPM to 1,000,000 PPM (100 %). This setting is accessed from the Alarm Relay Setup Menu by typing “2” on the RS-232 terminal.

4.1.2.10.3 Alarm-1 Descending

This setting configures Alarm-1 to either ascending or descending trip. Ascending is defined as Alarm-1 active when the oxygen concentration is above the Alarm-1 setpoint level. Descending is defined as; Alarm-1 active when the oxygen concentration is below the alarm-1 setpoint level. The descending setting may be set to “YES” or “NO”. This setting is accessed from the Alarm and Relay Setup Menu by typing “3” on the RS-232 terminal.

4.1.2.10.4 Alarm-2 Level setting (setpoint)

This setting sets the threshold level for Alarm-2. Depending on whether or not it is set to ascending or descending, Alarm-2 becomes active when the oxygen concentration is above or below this threshold

level. The Alarm-2 setpoint may be set anywhere from 0 PPM to 1,000,000 PPM (100 %). This setting is accessed from the Alarm Relay Setup Menu by typing "4" on the RS-232 terminal.

4.1.2.10.5 Alarm-2 Descending

This setting configures Alarm-2 to either ascending or descending trip. Ascending is defined as Alarm-2 active when the oxygen concentration is above the Alarm-2 setpoint level. Descending is defined as; Alarm-2 active when the oxygen concentration is below the alarm-2 setpoint level. The descending setting may be set to "YES" or "NO". This setting is accessed from the Alarm and Relay Setup Menu by typing "5" on the RS-232 terminal.

4.1.2.10.6 Relay Hold Time

This setting determines the minimum time that Alarm-1 and Alarm-2 relays will hold their active state once the Alarm-1 and Alarm-2 setpoint levels have been exceeded, regardless of the actual Oxygen concentration after Alarm-1 and Alarm-2 have been activated. The Hold Time level may be set anywhere from 0 to 300 seconds. This setting is accessed from the Alarm Relay Setup Menu by typing "6" or "H" on the RS-232 terminal.

4.1.2.10.7 Fault Relay Active during Warm-up

This setting determines the active status of the Fault relay during the Model 3100 warm-up routine (section 4.3.1.2). The activate setting may be set to "YES" or "NO". This setting is accessed from the Alarm Relay Setup Menu by typing "7" or "W" on the RS-232 terminal.

4.1.2.10.8 Relays Disabled after CAL/Setup

This setting determines the time that relays will be held in their last state before returning to RUN mode from the control panel or service port user menus. The relays disabled time may be set anywhere from 0 to 14,400 seconds. This setting is accessed from the Alarm Relay Setup Menu by typing "8" or "S" on the RS-232 terminal.

4.1.2.11 Analog output setup menu (U30)

The RS-232 Analog Output Setup menu U30 (see Figure 30) provides access to all of the settings related to the Analog Voltage Output (TB3-Pin5, TB3-Pin6) and Analog Current Output (TB3-Pin7, TB3-Pin8). It is accessed from the Setup Main Menu by typing "3" or "A" on the RS-232 terminal. To go back, use the <Esc> or "Q" key on the RS-232 terminal. Refer to Figure 9 for terminal block details.

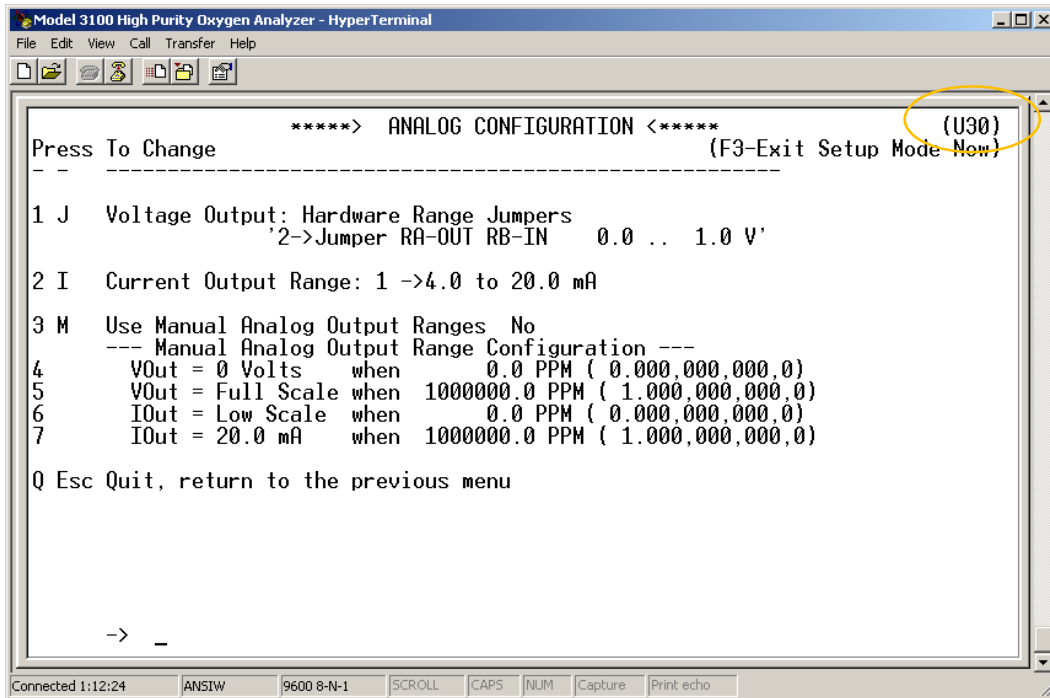

Fig. 30, Analog output configuration menu

4.1.2.11.1 Analog voltage output range

This menu sets the Analog Voltage Output full-scale value. Valid settings: 0 (0-5 VDC minimum to full scale), 1 (0-10 VDC minimum to full scale) or 2 (0-1 VDC minimum to full scale). This setting must match the RA and RB hardware jumper settings on the bottom of the main CPU PCB (section 4.1.3). This menu is accessed from the Analog Output Setup menu by typing “1” or “J” on the RS-232 terminal.

4.1.2.11.2 Analog current output range

This menu sets the Analog Current Output range. Valid settings: 0 (0-20mA minimum to full scale), or 1 (4-20mA minimum to full scale). This menu is accessed from the Analog Output Setup menu by typing “2” or “I” on the RS-232 terminal.

4.1.2.11.3 Manual analog output ranges

This menu is used to enable manual override of Analog output mapping to display range and to force minimum and maximum analog outputs to absolute oxygen measurement values. This menu is accessed from the Analog Output Setup menu by typing “3” or “M” on the RS-232 terminal.

4.1.2.11.4 Force minimum voltage output to O2 concentration

This menu sets the oxygen concentration at which the Analog Voltage output is at zero. This setting is entered in PPM increments, and can be anywhere from 0 PPM to 1,000,000 PPM (100%). This menu is accessed from the Analog Output Setup menu by typing “4” on the RS-232 terminal.

4.1.2.11.5 Force maximum voltage to O2 concentration

This menu sets the Oxygen concentration at which the Analog Voltage output is at maximum range (see section 4.1.2.11.1). This setting is entered in PPM increments and can be anywhere from 0 PPM to

1,000,000 PPM (100 %). This menu is accessed from the Analog Output Setup menu by typing “5” on the RS-232 terminal.

4.1.2.11.6 Force minimum current output to O2 concentration

This menu sets the oxygen concentration at which the Analog Current output is at minimum range (section 4.1.2.11.2). This setting is entered in PPM increments and can be anywhere from 0 PPM to 1,000,000 PPM (100 %). This menu is accessed from the Analog Output Setup menu by typing “6” on the RS-232 terminal.

4.1.2.11.7 Force maximum current output to O2 concentration

This menu sets the oxygen concentration at which the Analog Current output is at maximum range (see section 4.1.2.11.2). This setting is entered in PPM increments and can be anywhere from 0 to 1,000,000 (100 %). This menu is accessed from the Analog Output Setup menu by typing “7” on the RS-232 terminal.

4.1.2.12 Display/Auto-range setup (U14)

The RS-232 Display/Auto-Range Setup menu U14 provides access for the user to map the display and analog output range scale(s) of the Model 3100 to suit the application (see Appendix E – Range / Analog output Chart). The Analog Output Range may be set to: 1 (0-10 PPM), 2 (0-100 PPM), 3 (0-1,000 PPM), 4 (0-10,000 PPM), 5 (0-10 %), 6 (0-100 %), 8 (Auto-range). This menu is accessed from the Setup Main Menu by typing “4” or “G” on the RS-232 terminal. To go back, use the <Esc> or “Q” key on the RS-232 terminal.

4.1.2.13 RS-232 serial output configuration menu (U50)

This menu provides access to set the RS-232 serial communications options (see Figure 31). It is accessed from the Setup Main Menu by typing “5” or “S” on the RS-232 terminal. To go back, use the <Esc> or “Q” key on the RS-232 terminal.

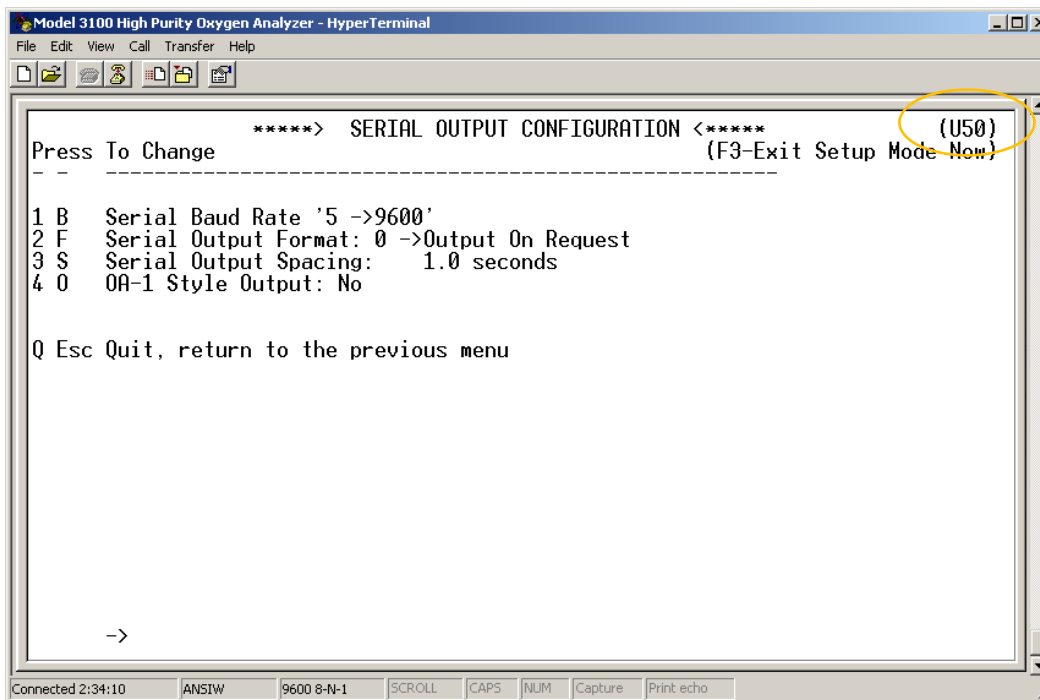

Fig. 31, RS-232 serial output configuration menu

4.1.2.13.1 Baud rate

This menu sets the RS-232 baud rate. Valid settings: 1 (300bps), 2 (1200bps), 3 (2400bps), 4 (4800bps), 5 (9600bps), 6 (19200bps) or 7 (38400bps). This menu is accessed from the RS-232 Serial Setup menu by typing “1” or “B” on the RS-232 terminal.

4.1.2.13.2 Automatic serial output format

This menu sets the format of the automatic timed RS-232 serial output (section 4.1.2.4). The timed serial output format may be set to: 0 (Output on Request), 1 (Human Readable), 2 (Machine Code), 3 (Machine Code with Checksum), 4 (Tab delimited) 5 (Model OA1 style; not used). This menu is accessed from the RS-232 Serial Setup menu by typing “2” or “F” on the RS-232 terminal.

4.1.2.13.3 Serial output spacing

This menu sets the rate at which the RS-232 sends complete ASCII data packets to the Service Port. The send rate can be set anywhere from 0 to 86,400 seconds. This menu is accessed from the RS-232 Serial Setup menu by typing “3” or “S” on the RS-232 terminal.

4.1.2.13.4 OA1 style output – NOT USED

4.1.2.14 Alarm setpoint lockout

If the Alarm Setpoint Lockout is enabled, the user may only view (not change) the Alarm-1 and Alarm-2 level settings. The Alarm Lockout setting is accessed from the Setup Main Menu by typing “6” on the RS-232 terminal. To go back, use the <Esc> or “Q” key on the RS-232 terminal.

4.1.2.15 Gas calibration lockout

If the Gas Calibration Lockout is enabled, the user may not change, but only view the Gas Calibration value. The Gas Calibration Lockout setting is accessed from the Setup Main Menu by typing “7” on the RS-232 terminal. To go back, use the <Esc> or “Q” key on the RS-232 terminal.

4.1.2.15.1 *User menu lockout*

If the Front Menu Lockout is enabled the user may not manually initiate any User mode from the control panel. The User Menu Lockout setting is accessed from the Control panel Locks menu by typing “8” on the RS-232 terminal. To go back, use the <Esc> or “Q” key on the RS-232 terminal.

4.1.2.16 Assume low-end (reference) calibration

The Model 3100 analyzer uses the Assume Low-End Calibration value (Zero Calibration Range in the setup menu) to recognize Reference Calibration gas (20.9 % oxygen) automatically, when applied to the oxygen sensor during calibration. When calibration gas applied outside of the factory-set Assume Low-End Calibration range of 18 to 24% oxygen, the analyzer assumes that it is Span gas. Refer to section 3.2.1 for a detailed calibration procedure.

WARNING: The Assume Low-End Calibration value is set to 18 to 24% oxygen at the factory, and it should not be adjusted by the user. If the user changes the Assume Low-End Calibration range, the Model 3100 will not operate properly.

4.1.2.16.1 **Calibration mode auto return to RUN**

This setting determines the minimum time that the Model 3100 allows after exiting from control panel or service port user menus, before returning the unit to on-line status. The calibration mode auto return setting is accessed from the Control panel Locks menu by typing “T” on the RS-232 terminal. To go back, use the <Esc> or “Q” key on the RS-232 terminal.

4.1.2.17 Line voltage – 208 Volt

The 208 Volt Line Voltage setting allows the user to set the AC supply voltage to the Remote Sensor Module. Note that the software settings must match the AC switch setting on the RSM module (refer to the equipment manual). The 208 Volt Line Voltage setting is accessed from the Control panel Locks menu by typing “L” on the RS-232 terminal. To go back, use the <Esc> or “Q” key on the RS-232 terminal.

4.1.3 Change factory settings via hardware jumpers

4.1.3.1 Analog voltage output

The Analog Voltage Output must be configured using the hardware settings. In addition, the software settings must match the jumper settings. Software changes are made via the Control panel User Setup menu (see section 4.1.1) or the Service Port RS-232 User Setup menu (see section 4.1.2.7).

4.1.3.1.1 Remove the unit from service

Make certain that all interfacing to the Model 3100 is disabled at the user device. Make sure that interrupting alarms, outputs, etc. will not interfere with normal process monitoring or control. Disconnect power from the Model 3100 unit. Disconnect the removable terminal blocks from the rear of the Model 3100 chassis. Follow all lock-out/tag-out procedures.

4.1.3.1.2 Change jumper settings

Turn the Model 3100 upside down to access the jumpers through the port provided (see Figure 32). Identify the appropriate jumper position (see Figure 33). Note that “shorted” indicates that a jumper is installed on the contacts. Use an insulated jumper-puller to remove and replace jumpers.

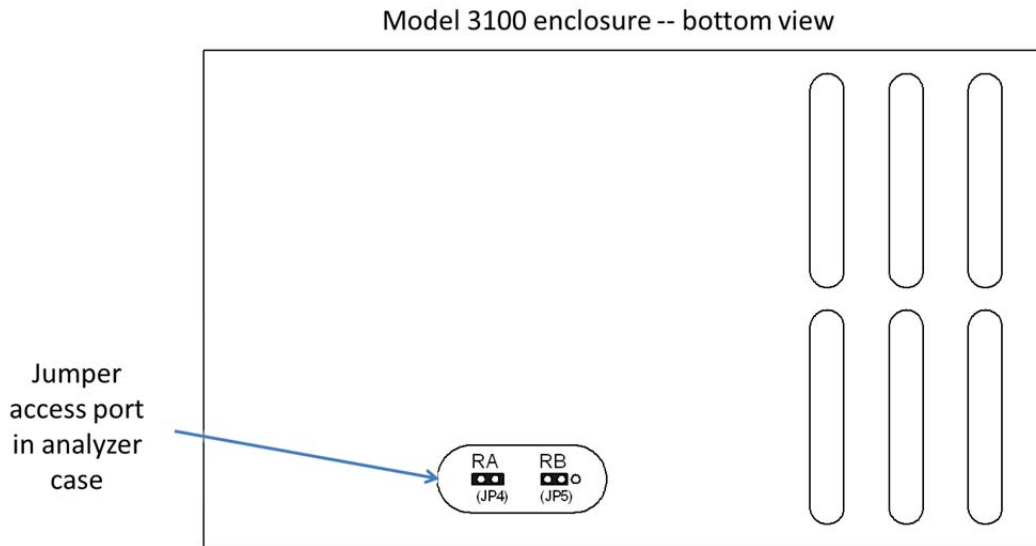

Fig. 32, Jumper setting access port

JP4 / JP5 jumpers (1=shorted; 0=open)		Select voltage output range
RA	RB	
0	1	$V_{out} = 0-1 \text{ VDC}$
0	0	$V_{out} = 0-5 \text{ VDC}$
1	0	$V_{out} = 0-10 \text{ VDC}$

Fig. 33, Jumper settings

4.1.3.1.3 Return to service

Replace cables, and terminal blocks. Reapply power. Change the Analog Voltage Output setting using the pushbuttons on the control panel or the RS-232 service port to match the new hardware settings. Perform a calibration check. Check the functionality of the changes to ensure that the new settings are recognized by the Model 3100.

4.2 Routine periodic maintenance

Maintenance for the Model 3100 oxygen analyzer is simple. Apart from the normal maintenance for any instrument, such as cleaning the chassis, wiping the display, and replacing the sensor, the Model 3100 does not require any major periodic servicing. Calibration of the sensor on a known gas source should be performed on a regular basis. The chart below should serve as a general guide for maintenance personnel (see Figure 34).

Task	Frequency		
	At commissioning	Annually	As required
Calibrate the sensor	✓	✓	✓
Clean the analyzer chassis and display panel with a soft cloth. Keep the ventilation openings unobstructed.		✓	✓
Validate the display to a known gas source			✓
Replace the oxygen sensor			✓ Sensor life expectancy 5 – 7 years

Fig. 34, Maintenance schedule

4.2.1 Validate display to a known gas source

With the Model 3100 analyzer in “RUN” mode, apply a Certified Standard Grade bottled gas to the RSM with an oxygen concentration within the analyzer’s configured range. Wait for the reading on the 7-segment LED display to stabilize. Record the reading and match it against the oxygen concentration indicated on the test gas bottle certification tag. Perform system calibration (see section 3.2.1) if the analyzer reading is out of accuracy tolerance. Refer to Appendix B Specifications.

4.3 Troubleshooting

4.3.1 Fault codes

When trouble occurs during normal operation of the Model 3100, the user has several tools available to aid in isolating the cause(s) of given symptoms. As a starting point, the user may use the control panel to enter into “View Active Faults” mode (section 3.2.4). The user may also view active faults and other useful information via the Service Port (section 4.1.2). In addition, there are four system Hot-Keys available to perform special functions, and to gather important information quickly and easily (Appendix D).

Descriptions of faults are given below, with indication of common causes. Refer to the appropriate sections of this manual for more details as needed. The Neutronics Remote Sensor Module equipment manual may be helpful in troubleshooting casualties related to that apparatus.

4.3.1.1 Fault Code 1 – Oven or sensor warming up

The “Oven or sensor warming-up” fault indicates that the oxygen sensor is being heated to its operating temperature after a fresh power up. The purpose of the alarm is to provide a control output to indicate that the sensor has not yet reached its operating temperature, and the model 3100 is not yet ready for in-service oxygen measurement.

4.3.1.2 Fault Code 2 – Relays are in standby mode

The “Relays are in standby mode” fault indicates that the user has aborted the control panel user mode menu properly (section 3.2.5), and the unit is in a stabilization period to allow time to sweep the sample lines with sample gas before returning the unit to on-line service. During the stabilization period, Alarm-1, Alarm-2, Fault, and Heater OK relays remain inactive, and held to their last state before the control panel user mode menu was accessed. The factory default setting for this period is 120-seconds. This setting is user-configurable (section 4.1.2.10.8).

4.3.1.3 Fault Code 3 – Device is in setup mode – service port

The “Device is in setup mode” fault indicates that the user has entered the user setup mode from the service port (section 4.1.2), and the model 3100 is not monitoring oxygen in the process. The 7-segment alphanumeric display will show “SU”. The Device is in Setup Mode fault will clear when the user returns the unit to RUN mode.

4.3.1.4 Fault Code 4 – Clean mode is active

The “Clean mode is active” mode indicates that the user has entered the sensor clean mode from the control panel (section 4.1.1.9). This parameter allows the user to enable a sensor self-cleaning cycle if the oxygen sensor has been exposed to chemicals or gases that could affect its performance. During sensor clean mode, the 7-segment alphanumeric display will alternately show “CLE” and the temperature of the sensor heater in degrees centigrade.

4.3.1.5 Fault Code 5 – Analog output range overflow

The “Analog output range overflow” fault indicates an O₂ reading that is above the range configuration entered in the model 3100 setup (section 4.1.2.12). Possible causes of fault code-5 may be: Incorrect calibration gases, contaminated calibration gases, or faulty calibration sampling lines/components, or faulty RSM sampling lines/components, system exposed to oxygen levels above the analyzer's configured range.

4.3.1.6 Fault Code 6 – Analog Output range underflow

The “Analog output range overflow” fault indicates an O₂ reading that is below the range configuration entered in the model 3100 setup (section 4.1.2.12). Possible causes of fault code-6 may be: Analog Range lower limit set to a value greater than zero (section 4.1.2.11.1)

4.3.1.7 Fault Code 7 – A/D appears to be defective

The “A/D appears to be defective” fault is NOT ACTIVE for the current version of the model 3100.

4.3.1.8 Fault Code 8 – A concentration reading is not yet available

The “concentration reading is not yet available” fault is active when the model 3100 is not ready for online service. It is active during warm-up, calibration and during fault code-2 relay standby.

4.3.1.9 Fault Code 9 – Temperature sender appears to be open

The “Temperature sender appears to be open” fault is NOT ACTIVE.

4.3.1.10 Fault Code 11 – Non-native display range

The “non-native display range” fault indicates an O₂ reading that is above the range configuration entered in the Model 3100 setup (section 4.1.2.12). Fault code-11 is active when fault code 5 is active. Possible causes of fault code-11 may be: Incorrect calibration gases, contaminated calibration gases, or faulty calibration sampling lines/components, faulty RSM sampling lines/components, faulty or failing sensor, system exposed to oxygen levels above the analyzer’s configured range.

4.3.1.11 Fault Code 12 – User calibration too large – NOT USED

4.3.1.12 Fault Code 13 – User calibration too small – NOT USED

4.3.1.13 Fault Code 14 – Oven temperature error

The “oven temperature error” fault indicates that during normal operation, the Remote Sensor Module (RSM) is consistently reporting unexpected temperatures from the Sensor Heater. Tolerance for the oven temperature error is + 0.2°C. Fault code-14 is also active during analyzer warm-up. Possible causes of fault code-14 are: Sensor heater failing, sensor heater control interface failure, or erratic/incorrect sensor heater power supply voltage.

4.3.1.14 Fault Code 15 – Bad user calibration

The “bad user calibration” fault indicates that the user has attempted to calibrate what appears to the Model 3100 as a faulty sensor. Possible causes of fault code 15 are: incorrect calibration gases, contaminated calibration gases, or contaminated calibration sampling lines/components, faulty RSM sampling lines/components, faulty sensor.

4.3.1.15 Fault Code 16 – Heater Failure

The “heater failure” fault indicates that during warm-up, the sensor heater is not reaching expected temperatures within configured time tolerances set at the factory. Possible causes of fault code-14 include: sensor heater hardware failure, failure in sensor heater control interface, or sensor heater power supply voltage incorrect or missing fault codes.

5 Appendices

5.1 Appendix A – Spare parts list

Part number	Description
5-06-4900-16-0	Instruction manual
C1-11-1220-03-0	Vac fuses for power supply board – 1A, 250 VAC, Slo-Blo – for Vac units only
C6-01-1000-73-0	RSM / Analyzer interface cable
C1-17-0052-00-0	Replacement terminal block – TB1
C1-17-0142-00-0	Replacement terminal block – TB2
C1-17-0112-00-0	Replacement terminal block – TB3

5.2 Appendix B – Specifications

Part number	Description	
Sensor type	Rapid-response zirconium oxide, ZR100	
Display	0.75" 7-segment LED digital display, 4 characters (displays O2 from 0.1 PPM to 100%)	
Display resolution	0.1 – 9.9 PPM	X.X
	10.0 – 99.9 PPM	XX.X
	100.0 – 999.9 PPM	XXX.X
	1000 – 9999 PPM	XXXX
	1 – 9.99 %	X.XX
	10 – 99.9 %	XX.X
	100%	XXX.X
Color-coded LEDs	RUN	Green
	FAULT	Yellow
	ALARM-1	Red
	ALARM-2	Red
Serial service port	Bi-directional RS-232	
Analog voltage output	0–1, 0–5, or 0–10 VDC	
Analog current output	Non-isolated 4 – 20 mA, 12 VDC, negative ground; powered by analyzer; maximum electrical load 250 Ohms	

Part number	Description	
Range ID voltage	0.1 – 9.9 PPM	3.13 VDC + 0.1VDC
	10.0 – 99.9 PPM	3.75 VDC + 0.1VDC
	100.0 – 999.9 PPM	4.38 VDC + 0.1VDC
	1000 – 9999 PPM	5.00 VDC + 0.1VDC
	1 – 9.99 %	6.25 VDC + 0.1VDC
	10 – 99.9 %	8.13 VDC + 0.1VDC
Relay outputs	Alarm-1	Field Adjustable Form C (SPDT) Voltage-free, 5A @ 250 VAC, 5A @ 30 VDC (configurable to fail-safe/non fail-safe and ascending/descending activation)
	Alarm-2	Field Adjustable Form C (SPDT) Voltage-free, 5A @ 250 VAC, 5A @ 30 VDC (configurable to fail-safe/non fail-safe and ascending/descending activation)
	Fault	Non-adjustable Form B (SPST) Voltage-free, 5A @ 250 VAC, 5A @ 30 VDC (non-fail-safe activation, non-configurable)
	Heater OK	Non-adjustable Form B (SPST) Voltage-free, 5A @ 250 VAC, 5A @ 30 VDC (non-fail-safe activation, non-configurable)
Measurement range	0-10 PPM 0-100 PPM 0-1000 PPM 0-10,000 PPM 0-10% 0-100 % O ₂	
Accuracy	± 2.0% of range @ standard temperature and pressure	
Response time	T ₉₀ < 5 seconds	
Warm-up time	None	
Humidity	0-95% non-condensing	
Power	VAC unit	90–264 VAC, 47–63 Hz, Single Phase, 3 Watts
	VDC unit	11–30 VDC, 3 Watts
Operating temperature	32° to 122° F (0° to 50° C)	
Storage temperature	23° to 122° F (-5° to 50° C)	
Weight	2 Lbs. (0.9 Kg)	
Mechanical	Faceplate	Height 3.75" x Width 7.00" NEMA 4, IP66
	Panel cut-out	Height 2.91" x Width 6.20"
	Electronics enclosure	Height 2.81" x Width 5.98" x 3.60" Depth NEMA 1, IP20
Warranty	1 year from date of shipment	

5.3 Appendix C – Analyzer factory configuration settings

Alarm and relay setup information	
Alarm-1/Alarm-2 Relays Failsafe/Non-Failsafe	Non-fail-safe
Alarm-1/Alarm-2 Relay Ascending/Descending	Ascending
Alarm-1 Trigger Level	50 PPM
Alarm-2 Trigger Level	100 PPM

Display range	
0–10 PPM Fixed	
0–100 PPM Fixed	
0–1,000 PPM Fixed	
0–10,000 PPM Fixed	
0–10 % Fixed	
0–100 % Fixed	
Auto Ranging	X

Analog voltage range	
0–1 VDC	X
0–5 VDC	
0–10 VDC	

Relay disable after CAL/setup	
120-seconds	X

RS-232 baud rate	
300 BPS	
1200 BPS	
2400 BPS	
4800 BPS	
9600 BPS	X
19200 BPS	
38400 BPS	

RS-232 dump rate	
1-second	X

RS-232 timed output format	
Output on Request Only	
Human Readable Format	X
Machine Code	
Machine Code With Checksum	
Tab Delimited (Spreadsheet)	

Supply voltage	
90 – 264 VAC, 47 – 63 Hz	X
11 – 30 VDC	

5.4 Appendix D – Control panel hot-key functions

For convenience in operating and troubleshooting, the Model 1100 has four (4) control panel hot-key functions that can be performed quickly via the control panel without entering the normal Control panel or Service Port user menus.

Keys pressed*	Description of function
UP + DOWN	Return to "RUN" mode from any user mode
UP + DOWN (hold both keys for 10 seconds *)	Run lamp test
DOWN then MODE (hold both keys for 10 seconds *)	Show sensor voltage
UP then MODE (hold both keys for 10 seconds *)	Re-start Model 1100

* Hold all keys or pushbuttons indicated until the 7-segment alphanumeric display shows "---" then release the pressed keys. To return to normal operation, press and release the same keys again.

5.5 Appendix E – Range / output chart

Range name	Measured range	Display	Analog range	Range ID voltage output
Auto range	0.1–9.9 PPM	X.X	0–10 PPM	3.13 VDC
	10.0–99.9 PPM	XX.X	0–100 PPM	3.75 VDC
	100.0–999.9 PPM	XXX.X	0–1,000 PPM	4.38 VDC
	1000–9999 PPM	XXXX.	0–10,000 PPM	5.00 VDC
	1–9.99 %	X.XX	0–10 %	6.25 VDC
	10–99.9 %	XX.X	0–100 %	8.13 VDC
	100%	XXX.		
Fixed range 0-10 PPM	0-9.9 PPM	X.X	0–10 PPM	3.13 VDC
Fixed range 0-100 PPM	0-99.9 PPM	XX.X	0–100 PPM	3.75 VDC
Fixed range 0-1000 PPM	0-999.9 PPM	XXX.X	0–1,000 PPM	4.38 VDC
Fixed range 0-10,000 PPM	0-9999 PPM	XXXX.	0–10,000 PPM	5.00 VDC
Fixed range 0-10%	0-9.99 %	X.XX	0–10 %	6.25 VDC
Fixed range 0-100%	0-99.9 %	XX.X	0–100 %	8.13 VDC
0-100%	100.00%	XXX.0		

6

Limited warranty

1. Because of the many and varied circumstances and conditions under which NEUTRONICS, INC.'s products are used, and because NEUTRONICS, INC. has no control over this actual use, NEUTRONICS, INC. makes no warranties which extend beyond the express provisions herein. NEUTRONICS, INC. MAKES NO IMPLIED WARRANTIES OF MERCHANTABILITY OR FITNESS. NEUTRONICS, INC. makes no express warranties beyond the following provisions, which only apply to the original purchaser.
2. NEUTRONICS, INC. only warrants to the original purchaser as follows: When the products and their component parts are properly installed and maintained in accordance with the published NEUTRONICS, INC. manuals, and if the product has not been modified or tampered with, then only the products actually manufactured by NEUTRONICS, INC. shall be warranted to be free from defects in material and workmanship for a period of one year from shipment by NEUTRONICS, INC., except NEUTRONICS, INC. sensors which shall be free of said defects for a period of time from date of shipment as specified in the NEUTRONICS INC. technical specifications for that specific sensor.
3. The original manufacturers' warranties apply to products and components not manufactured by NEUTRONICS, INC.

NON-ASSIGNABILITY OF WARRANTY

4. The warranty as set forth in these terms and conditions may not be assigned, transferred, sold, or alienated in any other way and extends only to the original purchaser.

PURCHASER'S EXCLUSIVE REMEDY

5. The original purchaser's sole and exclusive remedy, unless varied by written agreement with NEUTRONICS, INC., is that NEUTRONICS, INC. will, at NEUTRONICS, INC.'s option, repair or replace any defective part which is returned to NEUTRONICS, INC. within ninety (90) days of discovery of the defect.

DISCLAIMER OF CONSEQUENTIAL DAMAGES

6. In no event shall NEUTRONICS, INC. be liable for consequential damages, including but not limited to damages for loss of use, damages for lost profits, and damages for resulting harm to property other than the NEUTRONICS, INC. assemblies and their component parts.

Intended use for the Model 3100 analyzer

The Model 3100 analyzer was designed to provide the trained operator with useful information relating to the concentration of Oxygen. This information may be used in process control applications to detect oxygen contamination. Before implementation, the user must fully understand the operation and limitations of this instrument as well as the application for its use. The responsibility for the proper application, operation, installation, and maintenance of the Model 3100 analyzer is the sole obligation of the trained operator. The purchaser is required to ensure operators are properly trained in the use of this unit as well as in the possible hazards associated with its use or with the intended application. The purchaser must ensure that all of the proper warnings, labels, instruction manuals, lock outs, redundant components, hazard analysis, and system validation have been completed and provided to the trained operator before implementation of the Model 3100 instrument.