

BACHARACH[®]

The Measurable Difference

DRAFT GAUGE

Instruction 0013-9009
Rev. 5 - May 2010

WARRANTY

Bacharach, Inc. warrants to Buyer that at the time of delivery this Product will be free from defects in material and manufacture and will conform substantially to Bacharach Inc.'s applicable specifications. Bacharach's liability and Buyer's remedy under this warranty are limited to the repair or replacement, at Bacharach's option, of this Product or parts thereof returned to Seller at the factory of manufacture and shown to Bacharach Inc.'s reasonable satisfaction to have been defective; provided that written notice of the defect shall have been given by Buyer to Bacharach Inc. within one (1) year after the date of delivery of this Product by Bacharach, Inc. For full details concerning this warranty, contact Bacharach Inc.

World Headquarters
621 Hunt Valley Circle, New Kensington, PA 15068
Ph: 724-334-5000 • Fax: 724-334-5001 • Toll Free: 800-736-4666
Website: www.mybacharach.com • E-mail: help@mybacharach.com

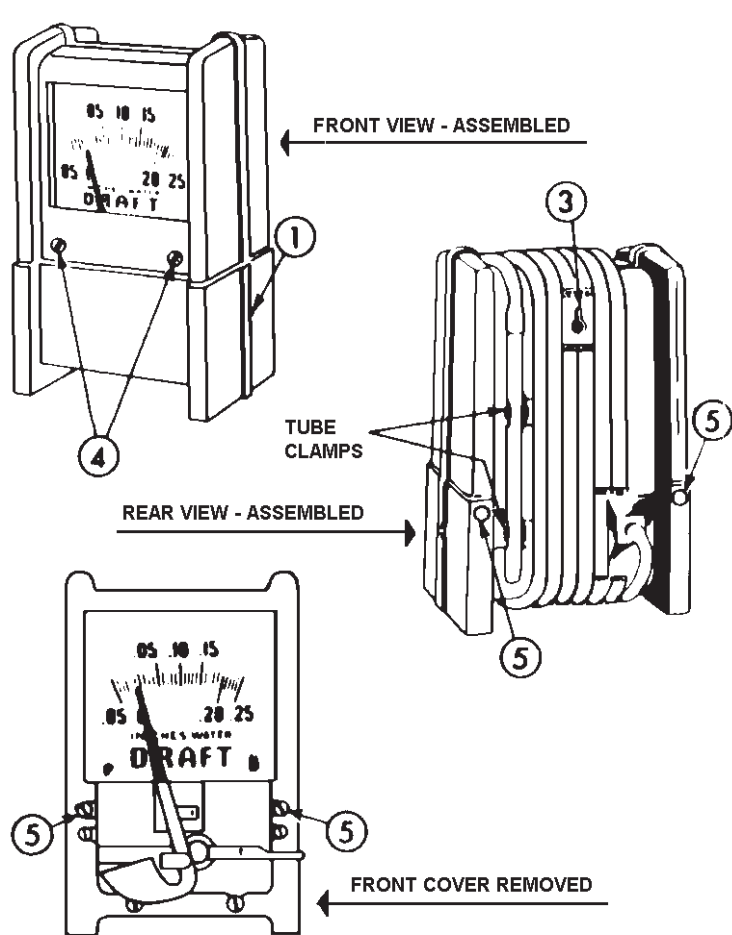

Figure 1. Draft Gauge

Mounting the Instrument

For portable use stand the gauge on a reasonably level surface convenient to the location for checking draft. Gauge may also be hung in an upright position using the Slotted Recess to receive a nail or screw head. For permanent installation remove the Screws and front cover, fasten to panel with two number 8 screws through the Mounting Holes, replace front cover and the Screws. Never locate gauge where temperature exceeds 110° F.

Connections

For portable use connect the gauge to a furnace with the 9 foot length of rubber tubing and metal draft tube provided. For permanent installation, make connection from panel to draft measuring point with copper tubing or pipe, solid tubing (no fittings) is preferred. At the end of the tubing provide a small tee with a short piece of rubber tubing as shown in Figure 3. Connecting lines over 50 feet in length is not recommended. Use as few bends as possible, and keep the connecting line to a minimum length. The following tubing sizes are recommended:

Up to 10 foot length	1/4 inch ID tubing
Up to 25 foot length	3/8 inch ID tubing
Up to 50 foot length	1/2 inch ID tubing

Zero Adjusting

When checking for zero, hold the draft tube near gauge or if permanently connected, break connecting line at panel. Zero is adjusted by moving the Adjusting Tab until the pointer is in line with the scales zero. For portable use, check zero each time the gauge is set up for use. For permanent installations (always disconnect the hose from the gauge before making the zero check) check zero at one or two week intervals.

Parts List for the Draft Gauge

- 0013-0014 Scale +.05 <0> -.25" H₂O
- 0013-0015 Scale +.05 <0> -1.0" H₂O
- 0013-0016 Scale +1 <0> -25mm H₂O
- 0013-0017 Scale +1 <0> -5mm H₂O
- 0013-0159 Scale +1 <0> -15mm H₂O
- 0013-0056 Leaf Spring Assembly for +.05" <0> -.25" or +1 <0> -5mm H₂O Range
- 0013-0057 Leaf Spring Assembly for +.05" <0> -1.0" or +1 <0> -25mm H₂O Range
- 0013-0058 Leaf Spring Assembly for +1" <0> -15" H₂O Range

- 0013-0006 Window
- 0013-0024 Screw
- 0013-0025 Screw
- 0013-0029 Pointer Assy
- 0013-0033 Calibrating Arm
- 0013-0034 Slide Stud
- 0013-0036 Washer
- 0013-0046 Draft Tube
- 0013-0047 Tubing
- 0013-0049 Cradle & Zero Adjuster
- 0013-0050 Diaphragm Cover
- 0013-0055 Diaphragm Assy
- 0013-0060 Back Cover
- 0013-0128 Front Cover
- 0013-0134 Front Cover Assy
- 0001-0627 Screws
- 0001-1636 Screws
- 0001-1974 Screws
- 0001-2486 Screw
- 0001-5107 Screw
- 0001-5110 Screw
- 0002-2160 Screws
- 0002-2986 Lock Nuts
- 0002-2990 Hex Nut
- 0002-3735 Speed Nuts
- 0002-4708 Washer
- 0005-4703 Pointer Stops

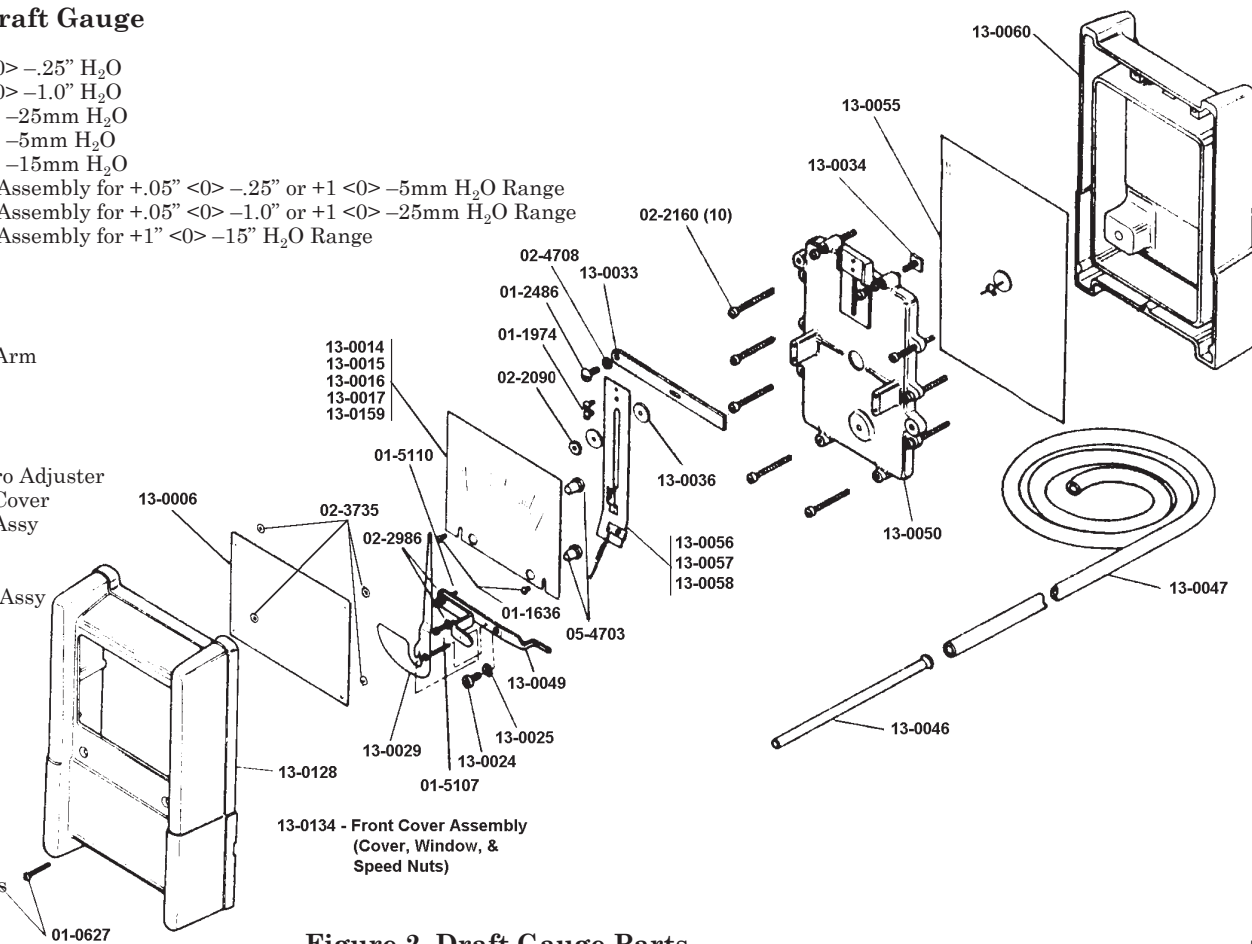

Figure 2. Draft Gauge Parts

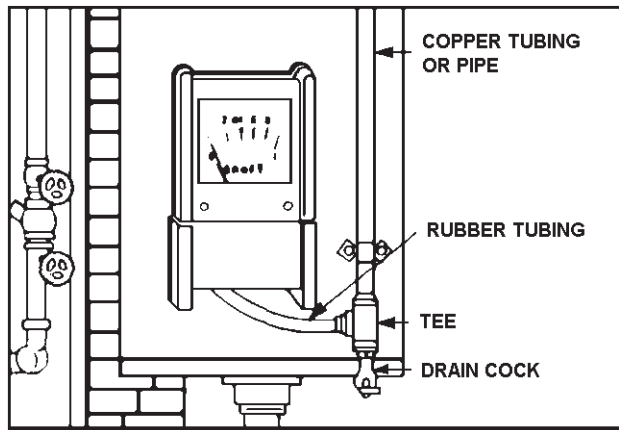
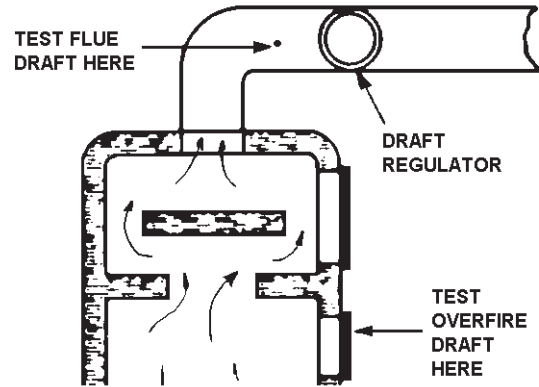

Figure 3. Mounting Draft Gauge

Locations for Checking Draft

Furnace manufacturer may require measurement of draft (a) in flue between regulator and furnace or (b) overfire between combustion space and heat exchanger (Figure 4). Locate sampling hole in flue 6" or more from draft regulator or damper toward furnace. Use awl with $\frac{1}{4}$ " shank for forming draft hole in light sheet metal. Make overfire measurement through blot hole in door or through air louvers. If necessary, drill $\frac{1}{4}$ " hole. In case of over sized hole or masonry setting, draft tube (replace with $\frac{1}{8}$ " pipe if necessary) should be inserted several inches beyond inside surface of flue pipe or furnace wall. For detailed instructions on check locations, see manufacturer's service or installation manual.

Figure 4. Draft Gauge Locations



Measuring Draft

Allow furnace to operate for several minutes, unwrap hose, place gauge on reasonably level surface, check zero, insert metal draft tube through draft hole. After about 30 seconds read draft from gauge scale.

Correct Draft

Recommendations for draft required for good performance must be obtained from the heating equipment manufacturer's installation or service manual. Some common causes of poor draft are shown in "Common Chimney Troubles".

Maintenance

Do not oil this gauge. Protect the gauge from shock, vibration and exposure to excessively high temperatures.

COMMON CHIMNEY TROUBLES

TROUBLE

REMEDY

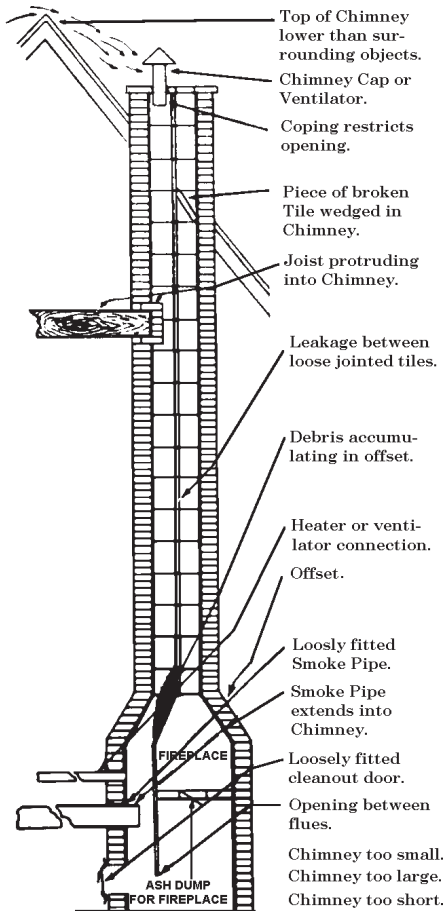

Extend chimney above all objects within 30 feet.

Remove.

Make opening as large as inside of chimney.

Break tile with a rod or weight on a string or wire.

Change support for joist so that Chimney will be clear.

Rebuild Chimney with a course of brick between flue tiles.

Break out with rod or weight, it may be necessary to open Chimney.

Remove.

Change to straight or to long offset.

Close leaks with cement.

Make end flush with inside of Chimney.

Close leaks with cement.

Close openings permanently.

Rebuild.

Rebuild.

Extend.