



SF₆ Portable Monitor

Instruction 3015-5150

Operation & Maintenance

Rev. 3- May 2010



WARRANTY

Bacharach, Inc. warrants to Buyer that at the time of delivery this Product will be free from defects in material and manufacture and will conform substantially to Bacharach Inc.'s applicable specifications. Bacharach's liability and Buyer's remedy under this warranty are limited to the repair or replacement, at Bacharach's option, of this Product or parts thereof returned to Seller at the factory of manufacture and shown to Bacharach Inc.'s reasonable satisfaction to have been defective; provided that written notice of the defect shall have been given by Buyer to Bacharach Inc. within two (2) years after the date of delivery of this Product by Bacharach, Inc.

Bacharach, Inc. warrants to Buyer that it will convey good title to this Product. Bacharach's liability and Buyer's remedy under this warranty of title are limited to the removal of any title defects or, at the election of Bacharach, to the replacement of this Product or parts thereof that are defective in title.

The warranty set forth in paragraph 1 does not apply to parts the Operating Instructions designate as having a limited shelf-life or as being expended in normal use (e.g., filters).

THE FOREGOING WARRANTIES ARE EXCLUSIVE AND ARE GIVEN AND ACCEPTED IN LIEU OF (I) ANY AND ALL OTHER WARRANTIES, EXPRESS OR IMPLIED, INCLUDING WITHOUT LIMITATION THE IMPLIED WARRANTIES OF MERCHANTABILITY AND FITNESS FOR A PARTICULAR PURPOSE: AND (II) ANY OBLIGATION, LIABILITY, RIGHT, CLAIM OR REMEDY IN CONTRACT OR TORT, WHETHER OR NOT ARISING FROM BACHARACH'S NEGLIGENCE, ACTUAL OR IMPLIED. The remedies of the Buyer shall be limited to those provided herein to the exclusion of any and all other remedies including, without limitation incidental or consequential damages. No agreement varying or extending the foregoing warranties, remedies or this limitation will be binding upon Bacharach, Inc. unless in writing, signed by a duly authorized officer of Bacharach.

Register Your Warranty by Visiting

www.mybacharach.com

Notice:

Product improvements and enhancements are continuous; therefore the specifications and information contained in this document may change without notice.

Bacharach, Inc. shall not be liable for errors contained herein or for incidental or consequential damages in connection with the furnishing, performance, or use of this material.

No part of this document may be photocopied, reproduced, or translated to another language without the prior written consent of Bacharach, Inc.

Copyright © 2010, Bacharach, Inc., all rights reserved.

BACHARACH® is a registered trademark of Bacharach, Inc. All other trademarks, trade names, service marks and logos referenced herein belong to their respective owners.

Initializing the Battery

The monitor is powered by a rechargeable battery pack located in a pouch at the back of the monitor's soft carrying case. Note that this step only needs to be done when first receiving the unit (or a replacement battery).

The TGA is shipped with the battery powered off to inhibit potential transportation problems.

Note: The red LED at the "E" marking on the battery is lit when the battery is powered on. It will extinguish if the battery is powered off or if it is completely discharged.

- 1) To initialize the battery, **push and hold** the TEST button until the red LED lights (10-15 seconds). When the TEST button is released, some or all of the adjoining 4 green LEDs will light. The green LEDs will extinguish in approximately 3 seconds, but the red LED will remain lit to indicate the battery is active.

4x green LEDs = full charge; 1x LED = very low charge

- 2) Briefly pushing the TEST button will indicate how much charge remains in the battery pack by the number of green LEDs lit.

Note that the TGA operates with the charger plugged in if the battery pack is powered off or discharged.

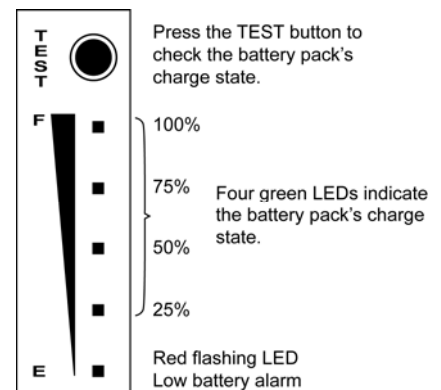

Table of Contents

1 INTRODUCTION	1
1.1 How to Use This Manual	1
1.2 Warning Statements	1
1.3 Caution Statements	1
1.4 Hazard Symbols on Monitor	1
1.5 Safety Precautions	2
1.5.1 Explosive Atmosphere	2
1.5.2 Misuse and Modifications to Monitor	2
1.5.3 Altitude Limit	2
1.5.4 Cleaning	2
1.6 Unpacking and Initial Checks	2
1.7 Shipping Precaution	2
1.8 Features and Capabilities	3
1.9 Functional Overview	3
2 SPECIFICATIONS	4
3 OPERATION	5
3.1 Front Panel Display and Controls	5
3.2 Inspection	5
3.3 Connecting Gas-Sample & Exhaust Lines	5
3.3.1 Overview	5
3.3.2 Connecting the Gas-Sample Line	6
3.3.3 Connecting the Exhaust Line (optional)	6
3.4 Gas Detector Operation	7
3.5 Time Weighted Average Operation	8
3.5.1 Overview	8
3.5.2 Starting a New or Continuing TWA/twa	8
3.6 Peak Reading Operation	9
3.7 Leak Detector Operation	9
3.8 Standby Mode	9
3.9 Battery – Testing and Charging	10
3.9.1 Testing the Battery	10
3.9.2 Charging the Battery	10
3.10 Display Screens	10
3.10.1 Initial Power ON	10
3.10.2 Filling the Purge-Air Bag	10
3.10.3 Data Display Screen	11
3.10.4 Function Screens	11
3.11 Working with System Faults	14
3.11.1 Functional Overview	14
3.11.2 Clearing / Silencing a Fault Alarm	14
3.11.3 Viewing the Faults Log	14
3.11.4 Fault Codes	15
3.12 Working with the Gas Alarm	16
3.12.1 Gas-Alarm Light	16
3.12.2 Silencing a Gas Alarm	16
3.13 Clearing the PPM & Faults Data	16
3.14 Working with the DIAG Function	16
3.14.1 Overview	16
3.14.2 Keypad Functions	16
3.14.3 First Diagnostic Screen	17
3.14.4 Second Diagnostic Screen	17
3.15 Working with the P-CHK Function	18
3.15.1 Overview	18
3.15.2 Keypad Functions	18

3.15.3 Screen Display.....	18
3.16 Print/Plot Logged Gas Levels.....	19
3.17 Downloading Stored Data to a Personal Computer.....	20
3.18 Importing Saved Data Into a Spreadsheet.....	21
4 MAINTENANCE.....	22
4.1 Disassembly.....	22
4.2 Internal Particulate / Hydrophobic Filter Replacement	23
4.3 Flashing Memory	24
4.4 Bench Replacement	25
4.4.1 Removing the IR Bench	25
4.4.2 Installing the New IR Bench	26
4.4.3 Adjusting IR Bench Emitter Drive Power Level.....	26
4.4.4 Adjusting the IR Bench Voltage.....	27
5 PARTS AND SERVICE.....	28
5.1 Replacement Parts & Optional Items.....	28
Replacement Parts.....	28
Item Description	28
Part Number	28
Item Description	28
Part Number	28
5.2 Service Centers	30

1 Introduction

1.1 How to Use This Manual

This manual provides important information on how to operate and service Bacharach's Sulfur Hexafluoride (SF₆) Portable Monitor.

To assure operator safety and the proper use of the monitor, please read, understand, and follow the contents of this manual.

If you have a working knowledge of gas monitors, you will find this manual useful as a reference tool. If you are new to the use of gas monitors, you can educate yourself about the principles of gas detection and the proper operation of this device by reading this manual thoroughly.

1.2 Warning Statements

The use of the word **WARNING** in this manual denotes a potential hazard associated with the use of this equipment. It calls attention to a procedure, practice, or condition, or the like, which if not correctly performed or adhered to, could result in personal injury or death.

1.3 Caution Statements

The use of the word **CAUTION** in this manual denotes a potential hazard associated with the use of this equipment. It calls attention to a procedure, practice, condition, or the like, which if not correctly performed or adhered to, could result in damage to the equipment.

1.4 Hazard Symbols on Monitor



This symbol indicates the need to consult this operating instruction manual when opening the enclosure.

WARNING: A potential risk exists if the operating instructions are not followed.



This symbol indicates the presence of electric shock hazards when the enclosure is opened.

WARNING: To avoid risk of injury from electric shock, do not open the enclosure when power is applied.

1.5 Safety Precautions

1.5.1 Explosive Atmosphere

Do not operate this equipment in the presence of flammable liquids, vapors or aerosols. Operation of any electrical equipment in such an environment constitutes a safety hazard.

1.5.2 Misuse and Modifications to Monitor

The protection provided by the monitor may be impaired if the monitor is used in a manner not specified by these instructions. Changes or modifications to this monitor will void the warranty.

1.5.3 Altitude Limit

6,562 ft (2,000 m)

1.5.4 Cleaning

Clean the outside of the monitor's case using a dry cloth — **DO NOT** use soap and water.

1.6 Unpacking and Initial Checks

Your SF₆ Portable Monitor was carefully inspected at the factory before shipment, and packed so as to be highly resistant to damage while in transport. When you receive the instrument, however, please unpack it promptly and make a visual inspection to make sure that no damage has occurred during shipment. Also check that all the following items have been received.

Item	Qty.	Part Number
SF ₆ Portable Monitor	1	3015-5148
Soft Carrying Case with Shoulder Strap	1	3015-4474
Battery Pack & Charger	1	3015-4654
Instruction Manual	1	3015-5150
External Filter Assembly	1	3015-5324
Stainless Steel Probe	1	3015-5326
Elbow	1	3015-3234
Tubing (3 ft)	1	0003-6182

If damage was found, immediately file a claim with the carrier. If an item is missing, please contact Bacharach's Service Department for assistance (refer to Section 5.2 *Service Centers*).

1.7 Shipping Precaution

When shipping the instrument by air, deflate the purge-air bag to prevent it from bursting due to changes in air pressure. Deflate the bag by selecting the **EMPTYBAG** function as described on Page 11.

1.8 Features and Capabilities

- Detects, measures, and displays the level of SF₆ gas in the area being monitored
- Measurement range of 0–1,000 ppm with a resolution of 1 ppm
- Self contained purge-air bag, allowing the monitor to be used in a contaminated atmosphere
- Automatically logs up to 200 gas readings that can be printed / plotted for analysis
- Eliminates false alarms with use of non-dispersive IR source and sample draw system
- Visual and audible gas alarm indicators that are turned ON when the detected gas level exceeds a user defined trip-point
- Extensive self diagnostics, providing both visual and audible indications when a fault occurs
- Battery powered, providing 8–12 hours of operation

1.9 Functional Overview

The Bacharach Sulfur Hexafluoride (SF₆) Portable Monitor is designed to detect, measure, and display the concentration of SF₆ gas in the area being monitored. To ensure accurate gas measurements, the monitor self-zeros every 4 minutes using its internal supply of fresh air.

During normal operation the SF₆ Monitor displays both the current gas level and the peak gas level detected on its front panel LCD. The monitor retains a log of previous readings that can be easily accessed at a later time for analysis.

Front panel indicators and an audible alarm are provided to signal gas alarm and instrument fault conditions. The audible alarm can temporarily be silenced by a push of a button, but will reactivate if the gas level is still above the alarm trip point after a user-defined time period has elapsed.

The SF₆ Monitor requires only minor periodic maintenance such as the occasional replacement of filters. The monitor incorporates active diagnostics that continuously check the system for proper operation. A front panel indicator is provided to alert an operator of system malfunctions, and fault codes are generated that enable the operator to quickly identify the cause of the fault.

2 Specifications

Product Type.....	Portable SF ₆ Gas Monitor
Measuring Range.....	0 to 1,000 ppm
Warm-Up Time.....	15 minutes
Detector Type.....	Infrared, Non-Dispersive
Sensitivity.....	1 ppm
Accuracy.....	±1 ppm
Response Time.....	90% of response within 3 seconds; 100% in 5 seconds
Temperature Drift.....	1.5 ppm per °C between purge cycles
System Noise.....	Less than 40dB(A) at 10 ft (3 m)
Operating Temp.....	32 to 122°F (0 to 50°C)
Ambient Humidity.....	5 to 90% RH (non-condensing)
Altitude Limit.....	6,562 ft (2,000 m)
Power.....	DC power pack, provides 8–12 hours of operation
Power Consumption.....	15 Watts
Front Panel.....	3 Indicator lights: ON – Green LED flashes during warm-up, and then glows steady during normal operation FAULT – Yellow LED flashes when there is a system fault ALARM – Red LED flashes when the gas level is above its alarm setting
Audible Alarm.....	Internal audible alarm programmable for any of the following conditions: OFF, FAULT/ALARM, ALARM
Dimensions.....	9D x 14.5L x 5W inches (229 x 368 x 127 mm)
Weight.....	Less than 9 lbs (4 kg) including battery
Valid Calibration Period to Specifications.....	12 months
Warranty.....	2 Years from date of shipment

3 Operation

3.1 Front Panel Display and Controls

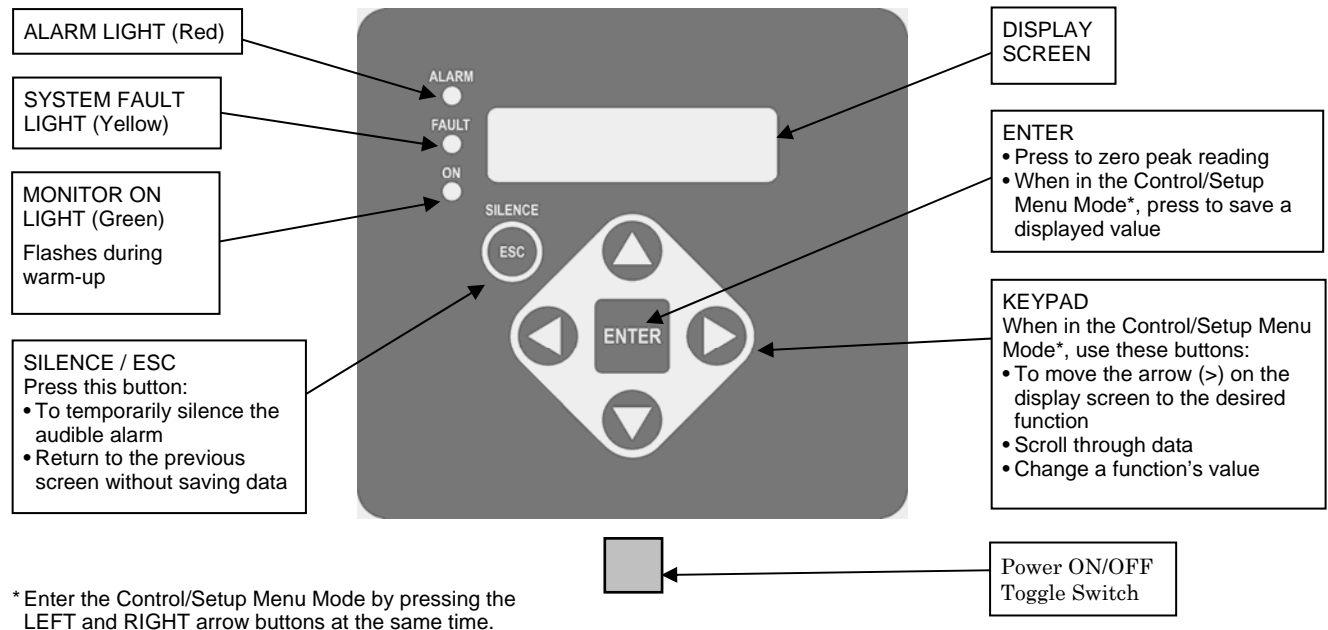

3.2 Inspection

The SF₆ Monitor has been thoroughly inspected and tested prior to shipment from the factory. Nevertheless, it is recommended that the monitor be re-checked prior to use. Inspect the outside of the enclosure to make sure there are no obvious signs of shipping damage. Open the enclosure and inspect the interior of the monitor for loose components that may have become dislodged during shipment. If damage is discovered, please contact your supplier for assistance.

3.3 Connecting Gas-Sample & Exhaust Lines

3.3.1 Overview

A single gas-sample line needs to be run from the SF₆ Monitor to the area to be monitored. If desired, an optional exhaust line can be installed to vent SF₆ gas away from the monitor.

3.3.2 Connecting the Gas-Sample Line

To connect the gas-sample line to the monitor, simply push the tubing onto the elbow connector and attach the elbow to the Gas Sample Port on the front of the monitor as shown in the illustration below.

The gas-sample line can be up to **50 ft (15.2 m)** in length. All tubing bends should have a radius of no less than 5" to insure proper airflow. If kinks or obstructions occur in the line the monitor may not function properly.

The end of this line should be placed near the potential leak source and positioned to reduce the possibility of mists, aerosols, oil, water, dust, or other contaminants being drawn into the monitor.

For added protection, an external filter (P/N 3015-5324) and probe (P/N 3015-5326) should be attached to the end of this line.

3.3.3 Connecting the Exhaust Line (optional)

The optional exhaust line functions to carry the exhausted gas sample away from the monitor.

The exhaust line can be up to **50 ft (15.2 m)** in length. Ideally this line should terminate outdoors in a location that is not exposed to the elements.

Connect the exhaust line to the monitor by firmly pushing the tubing onto the Exhaust Port's barbed fitting. If the exhaust line terminates outside the building, position the tubing so that no water or moisture can enter the line. Note that this line does not require a termination filter.

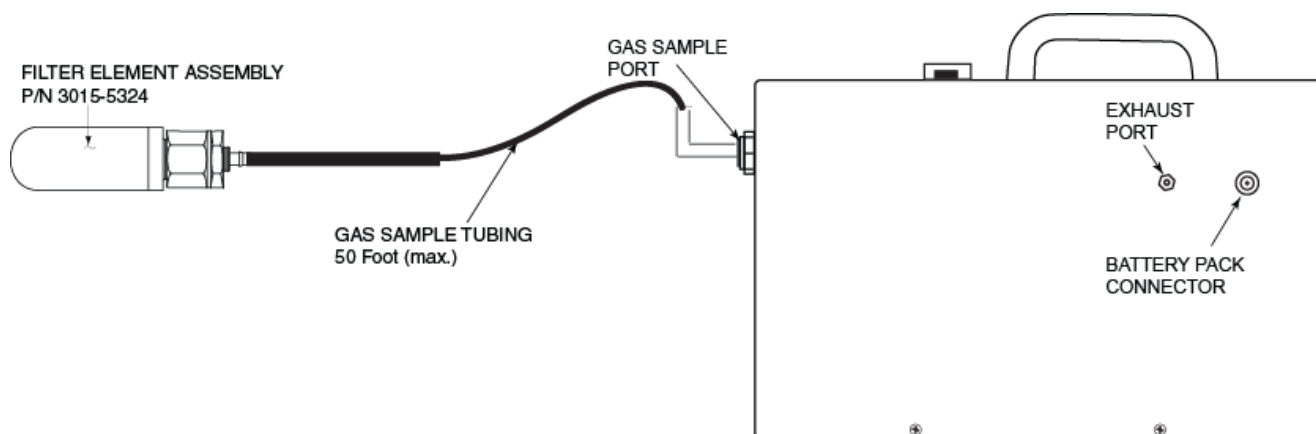

3.4 Gas Detector Operation



CAUTION: Operate the monitor in its horizontal position (handle facing upwards). Tilting the monitor to a vertical position while in operation may cause inaccurate measurements to occur.

Turn ON the monitor as follows:

1. Lift up the shield located in front of the handle
2. Press the red power ON/OFF toggle switch.
3. Observe monitor's firmware version is briefly displayed.
4. Observe that the **NEW TWA/twa** screen may appear, depending on the configuration of the monitor's TWA/twa function (refer to Section 3.5 for detailed TWA operation).
5. Observe the monitor starts counting down its warm-up period of 900 seconds (15 minutes).
6. At the end of warm up, take the monitor to an area than contains fresh air and press the **ENTER** button to fill the monitor's internal purge-air bag with clean, fresh air that is of the same temperature and humidity as the area being monitored for gas. **DO NOT** fill the purge-air bag in an area that is contaminated with SF₆ gas.

BACHARACH
VERSION x.xx

PRESS ENTER FOR
NEW TWA/twa

WARM UP
900

PURGE AIR EMPTY
(ENTER) TO FILL

RECHARGING PURGE
AIR...

MEASURE 2ndUNIT
100ppm SF6

PURGE 2ndUNIT
100ppm SF6

PURGE AIR EMPTY
<ENTER> TO FILL

After the purge-air bag is filled, observe the following as the monitor makes gas measurements in the area being sampled:

- **MEASURE** indicates when the monitor is actively measuring the level of SF₆ gas at the sampling point. The screen to the right shows that currently 100 ppm is being measured. The measurement cycle runs for 4 minutes.

A log of up to 200 previous measurements can be viewed using the **PPM LOG** function (Page 12), or printed as described in 3.16.

The **2ndUNIT** value (Blank, Peak PPM, Continuous TWA, or 8 Hr TWA) is user-selected (refer to **2ndUNIT** function on Page 13).

- **PURGE** indicates when the monitor is resetting its infrared detector to a baseline of 0 ppm using the air contained in the monitor's internal purge-air bag. The purge cycle runs for 10 seconds.

The monitor will operate for approximately 40 minutes before the purge-air bag needs refilled. When the message "PURGE AIR EMPTY" appears, take the monitor to a **clean, fresh-air environment** and press the **ENTER** button to refill the bag.

Work with gas alarms and system faults as follows:

ALARM (red) light turns ON if the detected gas level exceeds a programmed alarm point. An audible alarm also sounds if the **AUDALRM** function is activated (Page 11) Pressing the front panel **SILENCE** button turns OFF the audible alarm, but the **ALARM** light will continue to flash for as long as the detected gas level is above the alarm point. The audible alarm will reactivate if the gas-alarm condition is not cleared within the time period set by the **SILENCE** function (Page 13).

FAULT (yellow) light turns ON if a fault occurs (see Fault Code list on Page 15). An audible alarm also sounds if the **AUDALRM** function is activated (Page 11). Pressing the front panel **SILENCE** button turns OFF the audible alarm, but the **FAULT** light continues to flash for as long as the fault is present. The audible alarm will reactivate if the fault condition is not cleared within the time period set by the **SILENCE** function (Page 13). Both the **FAULT** light and audible alarm will automatically turn OFF after the cause of the fault has been eliminated. A log of the last 30 fault events can be viewed using the monitor's **FAULTS** function (Page 12).

3.5 Time Weighted Average Operation

3.5.1 Overview

In addition to displaying the current SF₆ level, the monitor can also calculate and display a **Time Weighted Average** ppm value. This value is available in two formats (8 Hour or Continuous). This provides users with the most appropriate data on their average ppm SF₆ exposure in the working environment.

TWA operation is selected by using the **2ndUNIT** function (Page 13).

The two TWA formats are identified by the appearance of either “TWA” or “twa” in the upper-right corner of the **Data Display** screen.

- **TWA** (upper case letters) is calculated over an 8-hour period. This format is designed to show the users’s average ppm SF₆ exposure level during a typical work day. After 8 hours has expired, an asterisk (*) will be displayed but the TWA will continue to be updated.

PURGE00TWA
 100ppm SF6

- **twa** (lower case letters) is continuously calculated over the operating time of the monitor. This mode is useful for monitoring an area for a few minutes or more and is the preferred mode of operation for checking operating room atmospheres.

PURGE 00twa
 100ppm SF6

3.5.2 Starting a New or Continuing TWA/twa

When the monitor is turned ON the following message appears if the monitor is set up to display TWA/twa.

PRESS ENTER FOR
 NEW TWA/twa

Press either . . .

- **ENTER** to start a new TWA/twa
- **ESC** to continue with the current TWA/twa.

Tip: If **NO** button is pressed within 60 seconds the monitor automatically continues with the current TWA/twa.

Note: During the time the monitor is OFF, the gas measurement is assumed to be zero and will be factored into the TWA/twa calculation.

After selecting whether to start or continue a TWA/twa, the next screen shows the current elapsed TWA/twa time.

ELAPSED TWA TIME
 IS xx MINUTES

Where: xx is the accumulated time used by the monitor in calculating the TWA/twa.

3.6 Peak Reading Operation

In addition to displaying the current SF₆ level, the monitor can also be set up to display its peak ppm measurement.

The peak reading display is selected by using the **2ndUNIT** function (Page 13).

PURGE	500pk
	100ppm SF6

The display above shows that currently the monitor is detecting 100 ppm SF₆ and that a peak measurement of 500 ppm has occurred.

The peak reading is reset by pressing the **ENTER** button.

3.7 Leak Detector Operation

The monitor can be configured to operate as a Leak Detector by setting the **AUDALRM** function (Page 11) to **LEAK DETECTOR**.

When configured as a Leak Detector, the monitor will produce a leak detector type of audible feedback. At zero ppm there will be a tic every 2 seconds with the tic rate increasing up to 20 tics per second when the ppm level reaches the **ALRMLVL** (Page 11) setting.

3.8 Standby Mode

After becoming operational, the monitor can be placed into a Standby Mode. When taken out of standby the monitor is ready for operation without waiting an additional 15 minutes to warm up. While in standby the monitor will stop taking gas samples and stops purging itself from the purge-air bag.

Place the monitor into its Standby Mode by pressing both the **ENTER** and **ESC** buttons at the same time.

STAND BY

Take the monitor out of standby by again pressing both the **ENTER** and **ESC** buttons.

When the monitor is taken out of standby the operator must refill the purge-air bag by pressing the **ENTER** button. Refilling the bag after coming out of standby re-establishes the monitor's ambient pressure reading and ensures that the purge-air bag is filled at the start of taking gas measurements.



WARNING: Fill the purge-air bag in a clean, fresh-air environment that is at the same temperature and humidity as the area being checked for gas. DO NOT fill the bag in an area that is contaminated with SF₆ gas.

PURGE AIR EMPTY <ENTER> TO FILL

RECHARGING PURGE AIR...

As soon as the purge-air bag has been refilled with fresh air, the **Data Display** screen appears and the monitor resumes normal operation.

3.9 Battery – Testing and Charging

3.9.1 Testing the Battery

The monitor is powered by a rechargeable battery pack located in a pouch at the back of the monitor's soft carrying case.

The battery's charge state can be checked by quickly pressing its **TEST** button and observing the number of LEDs that light. A fully charged battery pack will power the monitor for 8–12 hours.

A red flashing LED shows that the battery pack needs to be charged.

3.9.2 Charging the Battery

The battery pack can be recharged at any time, regardless of the battery's current charge state.

1. Plug the charger's AC line cord into any convenient 110/220 VAC, 50/60 Hz outlet. (An optional Car Charger is also available.)
2. Plug the charger's output connector into the charge jack of the battery pack. Observe the following:
 - The charger's power indicator lights red while the battery pack is being charged.
 - The charger's power indicator lights green when charging is complete.
 - Charging time is 3 to 4 hours for a fully discharged battery pack.

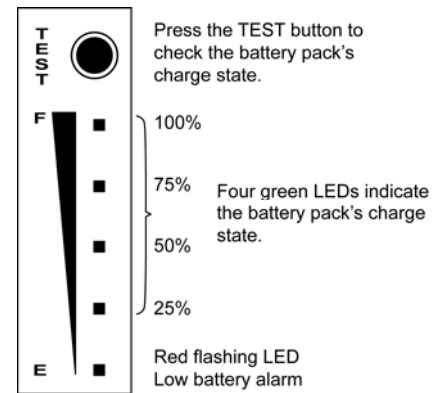

3.10 Display Screens

3.10.1 Initial Power ON

When the monitor is first powered ON, all front panel lights turn ON and a splash screen appears showing the monitor's current firmware revision level. After a brief moment the **Warm Up** screen is displayed along with the front panel **ON** light (green) blinking.

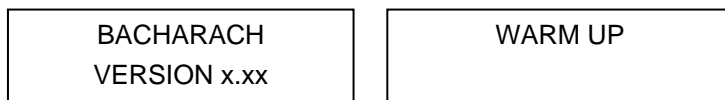

The monitor requires 15 minutes to warm up from a cold start; after which, the **ON** light glows steady and the **Data Display** screen appears.

3.10.2 Filling the Purge-Air Bag



CAUTION: Fill the purge-air bag in a clean, fresh-air environment that is at the same temperature and humidity as the area being checked for gas. DO NOT fill the bag in an area that is contaminated with SF₆ gas.

The following message is displayed and an audible alarm is sounded when the monitor's purge-air bag is empty. This message appears immediately after warm-up, and approximately every 40 minutes during normal operation. Press the **ENTER** button to start the refill process.



After the air bag has been filled, the monitor starts or resumes normal operation by displaying the **Data Display** screen.

3.10.3 Data Display Screen

MEASURE 2ndUNIT 100ppm SF ₆	PURGE 2ndUNIT 100ppm SF ₆
---	---

During normal operation the **Data Display** screen shows when the monitor is performing the following two functions:

MEASURE indicates that the monitor is actively measuring gas. In the screen shown above the monitor is currently detecting 100 ppm of SF₆ gas. The **2ndUNIT** value (Blank, Peak PPM, Continuous TWA, or 8 Hr TWA) is user-selected (refer to **2ndUNIT** function on Page 13). The measurement cycle runs for 4 minutes.

PURGE is displayed when the monitor is resetting its infrared detector to a baseline of 0 ppm using the fresh air in the monitor's internal purge-air bag. The purge cycle runs for 10 seconds.

3.10.4 Function Screens

The Function screens are used to set up the monitor and display stored data.

From the **Data Display** screen, press both the **Keypad Left** and **Right** buttons at the same time to display the first **Function Menu** screen. Next, use the **Keypad** buttons to move the arrow (>) until it points to the desired function, and then press the **ENTER** button to select that function.

>FILLBAG EMTYBAG ALRMLVL AUDALRM	>PPM LOG LOG INT FAULTS DIAG	>SILENCE P-CHK GAS CLOCK
>2ndUNIT PRINT PLOT PC-DUMP		

Once a function has been selected, use the **Keypad** to scroll through the displayed data or to change a parameter associated with that function. Press **ENTER** to save any newly entered parameters. Press the **ESC** button to return to the previous screen without saving.

Note that if no buttons are pressed within 90 seconds after selecting a function, the unit returns to the **Data Display** screen.

FILLBAG – Press **ENTER** to manually fill the purge-air bag.



WARNING: *Fill the purge-air bag in a clean, fresh-air environment that is at the same temperature and humidity as the area being checked for gas. DO NOT fill the bag in an area that is contaminated with SF₆ gas.*

FILLING BAG...

EMTYBAG – Press **ENTER** to manually empty the purge-air bag. Use this function to drain the bag if it becomes contaminated with gas.

DRAINING BAG...

ALRMLVL – Detected gas level that causes the front panel **ALARM** (red) light to turn ON and the audible alarm to sound (if AUDALRM function is set to ALARM or ALARM/FAULT).

EDIT ALARM LEVEL
300 ppm

AUDALRM – The internal audible alarm is programmable to function as follows:

AUDIBLE ALARM IS
ALARM

- **OFF** – Audible alarm is disabled.
- **ALARM** – Alarm sounds when detected gas level exceeds the ALRMLVL level as evidenced by the front panel ALARM (red) light turning ON.
- **ALARM/FAULT** – Alarm sounds when either the detected gas level exceeds the ALRMLVL value, or if a system fault occurs, as evidenced by the front panel ALARM (red) light or FAULT (yellow) light turning ON.
- **LEAK DETECTOR** – When selected, the monitor will produce a leak detector type of audible feedback. At zero ppm there will be a tic every 2 seconds with the tic rate increasing up to 20 tics per second when the ppm level reaches the ALRMLVL setting.
- **TWA ALARM** – Audible alarm sounds when the TWA or twa, whichever is selected by the **2ndUNIT Function**, exceeds the ALARMLVL value.

The audible alarm can be temporarily silenced by pressing the **SILENCE** button (Page 13).

PPM LOG – Contains records of the last 200 measurements. Each record shows the measurement's date, time, and ppm level. Measurements are logged at an interval determined by the **LOG INT** function. After all 200 locations are filled the newest entries overwrite the oldest entries.

```
#025  7PPM @
07/11/05 15:35
```

Use the **Keypad Up** and **Down** buttons to change the record number by a factor of 1. Use the **Right** and **Left** buttons to change the record number by a factor of 10. Press **ESC** to return to the previous screen.

To the right, record #025 shows that a gas level of 7 ppm was measured on 07/11/2005 at 3:35 PM.

The PPM Log can be cleared per Section 3.12.

LOG INT – Sets the interval at which measurements are logged to memory from 1 to 9999 minutes. Factory default is 1 minute. The logged measurements can be viewed using the **PPM LOG** function. Use the **Keypad** to enter the desired value, and then press **ENTER** to save that value and return to the previous screen.

```
LOG INTERVAL IS
0001 min
```

FAULTS – Contains records of the last 30 fault events. The most recent event is displayed when the **Fault** screen is first displayed. After 30 events have been recorded, the newest record overwrites the oldest. Each record lists an event's numeric fault code (refer to Section 3.11) plus the date and time at which the event occurred. Use any of the **Keypad** buttons to scroll through the other fault events. Press **ESC** to return to the previous screen.

```
#15 <1000> @
07/11/05 12:37
```

To the right, record #15 shows that a Purge Flow Fault (fault code <1000>) occurred on 07/11/2005 at 12:37 PM.

DIAG – Enters the diagnostic function. Refer to Section 3.14.

```
4.2159v <0000>
29.05cD 14.58psi
```

SILENCE – Sets the length of time the internal audible alarm is turned OFF when the front panel **SILENCE** button is pressed. The factory default is 30 seconds. If the cause of the gas-alarm has not been cleared at the end of this time period, the internal audible alarm will reactivate. Use the **Keypad** to enter the desired time period, and then press **ENTER** to save that value and return to the previous screen.

```
SILENCE TIMEOUT
0030 sec
```

P-CHK – The **Pressure Check** function displays the current manifold pressure and the stored ambient pressure in psia, along with the difference between these two pressures and the current fault code. Refer to Section 3.15.

```
14.07 * AMB14.05
-0.02dif <1000>
```

GAS – Displays Sulfur Hexafluoride (SF₆) as the gas being monitored. No other gas types are available for selection.

```
SELECT GAS TYPE
SF6
```

CLOCK – Sets the monitor's date and time. Use the **Keypad** to enter the correct date and time, and then press **ENTER** to save those values and return to the previous screen. Note that time is displayed in a 24 hour format, while the date is displayed as mm/dd/yy.

```
SET DATE & TIME
07/11/05 15:30
```

2ndUNIT – One of following second measurements can be selected to appear in the upper-right hand corner of the **Data Display** Screen:

- **NONE** – Blank
- **Peak PPM** – Peak gas reading
- **Cont twa** – Time Weighted Average calculated on a continuous basis
- **8hr TWA** – Time Weighted Average calculated over an 8 hour period

```
MEASURE 00500pk
100ppm SF6
```

PRINT – Refer to Section 3.16 *Print/Plot Logged Gas Levels*.

```
2ndUNI >PRINT
PLOT PC-DUMP
```

PLOT – Refer to Section 3.16 *Print/Plot Logged Gas Levels*.

```
2ndUNIT PRINT
>PLOT PC-DUMP
```

PC-DUMP – A personal computer can be connected to the monitor's DB9 RS-232 connector (refer to illustration in Section 3.16) for the purpose of downloading logged ppm measurements. These measurements can later be analyzed using any common spreadsheet program. Refer to Section 3.17 for detailed instructions on how to transfer stored data to a personal computer.

```
2ndUNIT PRINT
PLOT >PC-DUMP
```

3.11 Working with System Faults

3.11.1 Functional Overview

If a system malfunction occurs (see Fault Code list, Page 15), the front panel **FAULT** light will flash and the audible alarm, if activated (refer to **AUDALRM** function Page 11), will start beeping.

3.11.2 Clearing / Silencing a Fault Alarm

The **FAULT** light and audible alarm will automatically turn OFF after the cause of the fault has been eliminated.

Pressing the **SILENCE** button while a fault condition still exists causes the internal audible alarm to turn OFF for a period of time as set by the **SILENCE** function (Page 13). The front panel **FAULT** light will continue to flash as a reminder that a fault condition still exists. At the end of the silence period if the cause of the fault has not been corrected the audible-alarm circuit will reactivate.

3.11.3 Viewing the Faults Log

From the **Data Display** screen, press any of the **Keypad** buttons to display the first **Function Menu** screen. Next, use the **Keypad** buttons to move the arrow (>) until it points to the **FAULTS** function, and then press the **ENTER** button to display the **Faults Log** screen.

```
#03 <0800> @
07/11/05 08:17
```

```
#04 <0000> @
07/11/05 09:00
```

The **Faults Log** screen shows the monitor's current fault status. If the fault is still present when the **FAULTS** function is selected, then the current cause of the fault is displayed along with the date and time it occurred. If the cause of the fault has been cleared, then the **Faults Log** screen will show <0000> along with the date and time the fault was cleared. Use the **Keypad** buttons to scroll through the fault log. In the screens shown to the left, record #03 shows that a Sample Flow Fault (fault code <0800>) occurred on 07/11/2005 at 08:17 AM, while record #04 shows that the fault was cleared on 07/11/2005 at 9:00 AM.

```
FAULT CODE<1800>
12 SAMPLE FLOW
```

```
FAULT CODE<1800>
13 PURGE FLOW
```

The cause of the fault is identified by a numeric fault code. To convert the fault code into a text description of the fault, first press the **ENTER** button and then use the **Keypad** buttons to scroll through the display until the text description of the fault appears. If the fault code is a combination of two or more faults, then continue to use the **Keypad** buttons until all fault text descriptions have been displayed. For example, the fault code <1800> represents the combination of both a Sample Flow <0800> and a Purge Flow <1000> fault as shown to the left.

The Fault Log can be cleared as described under the heading *Clearing the PPM and Faults Data* (Section 3.13).

3.11.4 Fault Codes

FAULT CODES ARE ADDITIVE. For example: A fault code of <0003> indicates that both a Box Temperature Fault <0001> and a Bench Temperature Fault <0002> have occurred.

<0001> Box Temperature Fault: Enclosure temperature is outside normal range (or IR detector has failed). Check that the monitor is not being subjected to extreme temperatures. Use the **DIAG** function to check the Box Temperature.

<0002> Bench Temperature Fault: Optical bench is outside normal operating range (or IR detector has failed). Check that the monitor is not being subjected to extreme temperatures.

<0004> Manifold Pressure Fault: The manifold pressure is outside its normal operating range (or IR detector has failed). Enter the **DIAG** function and record ALL data. Call the factory with this information for further instructions.

<0040> Fill Flow: The purge-air bag's pressure drop is outside expected limits. Use the **EMPTYBAG** and **FILLBAG** functions to refill the purge-air bag. If the fault still occurs, check for a punctured bag or disconnected tubing.

<0080> Over Range Fault: Monitor exposed to a gas level that exceeded 65,000 ppm.

<0100> Zero Filter Fault: The air-purge bag is contaminated with gas. Take monitor to a clean-air area and use the **EMPTYBAG** and **FILLBAG** functions several times to decontaminate the purge-air bag.

<0200> Gain Set Fault: The digipot autotune sequence has failed. This fault will only occur on first boot up or after a firmware upgrade. Call the factory for further instructions.

<0400> A/D Fault: A fault has occurred in the analog-to-digital circuitry. Contact the factory with this information for further instructions.

<0800> Sample Flow Fault: Check for: A restriction in the gas-sample inlet or exhaust; a blocked internal filter; or a failed pump.

<1000> Purge Flow Fault: Check for: A restriction in the gas-sample exhaust; a blocked internal filter; or a failed pump. Once the purge air stream has been restored, the monitor will return to normal operation after it completes a purge cycle.

<2000> Bag Fill Time: The purge-air bag did not fill within the expected time allotment, or too many purge cycles occurred indicating a leak in the purge-air system. Check for a punctured bag or disconnected tubing.

<4000> Zero Range Fault: The IR detector's output voltage is out of tolerance. Enter the **DIAG** function and record all data. Call the factory with this information for further instructions.

<8000> Clipping Fault: The detector voltage may be out of tolerance. Use the **DIAG** function to check the IR detector voltage. Call the factory with this information for further instructions.

3.12 Working with the Gas Alarm

3.12.1 Gas-Alarm Light

If the detected gas level reaches the gas-alarm level as set by the **ALRMLVL** function, the front panel **ALARM** (red) light will flash and the audible alarm, if activated (refer to **AUDALRM** function on Page 11), will start beeping. The **ALARM** light and audible alarm will automatically turn OFF once the detected gas level drops below the gas-alarm level.

3.12.2 Silencing a Gas Alarm

Pressing the **SILENCE** button while the alarm circuit is activated causes the audible alarm to turn OFF for a period of time as set by the **SILENCE** function (Page 13). The front panel **ALARM** light will continue to flash as an indication that an alarm condition still exists. At the end of the silence period if the detected gas level is still above the gas-alarm level the audible alarm will reactivate.

3.13 Clearing the PPM & Faults Data

Up to 200 gas measurements and 30 fault events are stored by the monitor.

To clear stored data, first display the data to be cleared by selecting the **PPM LOG** or **FAULTS** function per Section 3.10.4. Next, press both the **ENTER** and **Keypad Right** buttons at the same time. A single, long tone should be heard when the data has been successfully cleared.

3.14 Working with the DIAG Function

3.14.1 Overview

The **DIAG** function displays sensor data and status information useful to a service technician for troubleshooting various fault conditions. Explanations of the data shown in these screens are given below.

3.14.2 Keypad Functions

From the **Data Display** screen, press any one of the **Keypad** buttons to display the first **Function Menu** screen. Next, use the **Keypad** buttons to move the arrow (>) until it is next to the **DIAG** function, and then press **ENTER** to display the first of two **Diagnostic** screens.

Press the **Keypad Up** button to toggle between the **First** and **Second Diagnostic** screen.

3.14.3 First Diagnostic Screen

4.20885v <0000> 29.05cD 14.58psi	Bench Voltage Detector Temperature °C * Pressure Reading	Fault Code
0.00075n <0000> 35.40cB 14.59psi	Noise Box Temperature °C * Pressure Reading	Fault Code

In the **First Diagnostic** screen, the user can toggle between displaying Bench Voltage / Detector Temperature, and Noise / Box Temperature by pressing the **Keypad Right** button.

Bench Voltage – This is the current peak-to-peak output of the IR detector. In the absence of gas this value can range from 3.90000V to 4.50000V.

Noise – The Noise value is a 16 point running average of the noise portion of the IR detector's output. This reading is valuable mainly when gas is NOT present.

Detector Temperature – This is the current detector temperature in °C.

Box Temperature – This is the current internal enclosure temperature in °C.

Fault Code – Current fault code. A value of <0000> indicates that no faults are being detected.

Pressure Reading – This is the pressure as measured every purge cycle with the sample pump off and the gas-sample inlet open. Its value is weather and altitude dependent and can range from 10.0 to 15.5 PSIA.

Purge Valve Asterisk (*) – The purge valve can be opened and closed by pressing the **Keypad Left** button. An asterisk appears on the display when the purge valve is *open* causing the monitor to draw air from its purge-air port.

3.14.4 Second Diagnostic Screen

0.1ppm 0.01 0.00004au 4.210v	PPM Level Avg. Absorption Unit * Detector Voltage	µMole/Liter
---------------------------------	--	-------------

PPM Level – Parts Per Million Level is the current detected gas level, and is the volume concentration referenced to standard temperature and pressure.

Average Absorption Unit – This is the optical absorbency. In the absence of gas the absorbency is 0.00000 au. When sampling gas, its value varies proportionally with the gas concentration.

µMoles/Liter – This is the absolute concentration in micro-moles per liter of gas.

Detector Voltage – This is a running average of the IR detector's bench voltage.

Purge Valve Asterisk (*) – The purge valve can be opened and closed by pressing the **Keypad Left** button. An asterisk appears on the display when the purge valve is *open* causing the monitor to draw air from its purge-air port.

3.15 Working with the P-CHK Function

3.15.1 Overview

The **P-CHK** function (Pressure Check function) (Page 13) is useful to a service technician for troubleshooting a flow-fault problem. The monitor will trigger a flow fault if the pressure drop from ambient is less than 0.2 psi during a purge cycle, and 0.5 psi during a measurement cycle.

3.15.2 Keypad Functions

From the **Data Display** screen, press both the **Keypad Left** and **Right** buttons at the same time to display the first **Function Menu** screen. Next, use the **Keypad** buttons to move the arrow (>) until it points to the **P-CHK** function, and then press **ENTER** to display the **Pressure** screen.

The **Keypad Left** button toggles the purge valve open and closed. Note that an asterisk (*) appears when the purge valve is *open* causing the monitor to draw air from the purge-air bag.

The **Keypad Down** button toggles the pump ON and OFF.

Pressing the **ENTER** button stores the current manifold pressure shown on the left to the ambient pressure shown on the right (must be done with the pump OFF).

3.15.3 Screen Display

14.59 AMB14.75	Current Manifold Pressure	*	Stored Ambient Pressure
-0.16dif <0000>	Pressure Difference		Fault Code

Current Manifold Pressure – Current manifold pressure in psia.

Stored Ambient Pressure – Stored ambient pressure in psia.

Pressure Difference – Difference between the current manifold pressure and the stored ambient pressure.

Fault Code – Current fault code (Page 15).

Purge Valve Asterisk (*) – The purge valve can be opened and closed by pressing the **Keypad Left** button. An asterisk appears on the display when the purge valve is *open* causing the monitor to draw air from the purge-air bag.

3.16 Print/Plot Logged Gas Levels

A printout or plot of the last 200 SF₆ ppm measurements can be made by connecting the optional Bacharach printer and printer cable to the monitor as follows (refer to Section 5.1 for printer and cable part numbers):

1. For a printout or plot to be made, the monitor must have been set up to record gas measurements using the **LOG INT** function (Page 12).
2. Interconnect the RS-232 connectors located on the printer and monitor.
3. If not already done, refer to the printer manual and set the printer's communication parameters to:
 - Data bit = 8
 - Parity = None
 - Baud rate = 19200
 - Handshaking = DTR
4. From the **Data Display** screen, press both the **Keypad Left** and **Right** buttons at the same time to display the first **Function Menu** screen. Next, use the **Keypad** buttons to move the arrow (>) until it points to either **PRINT** to produce a printout, or **PLOT** to generate a plot.
5. Press **ENTER** to start the print/plot process.

2ndUNIT >PRINT
PLOT PC-DUMP

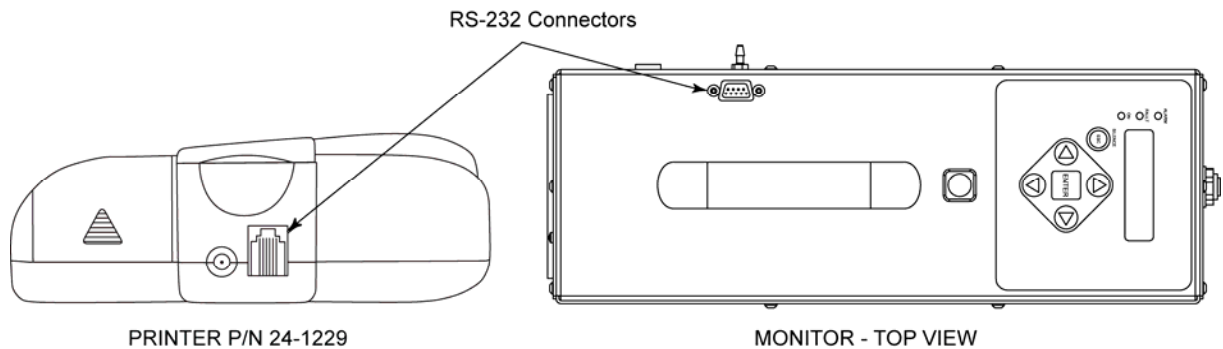

EXAMPLE PRINTOUT
Date / Time / PPM / Reading #

DATE	TIME	PPM	READING #
07/05/07	11:34	0PPH	0001 OF 194
07/05/07	11:35	45PPH	0002 OF 194
07/05/07	11:36	45PPH	0003 OF 194
07/05/07	11:37	44PPH	0004 OF 194
07/05/07	11:38	46PPH	0005 OF 194
07/05/07	11:39	45PPH	0006 OF 194
07/05/07	11:40	44PPH	0007 OF 194
07/05/07	11:41	44PPH	0008 OF 194
07/05/07	11:43	45PPH	0009 OF 194
07/05/07	11:44	45PPH	0010 OF 194
07/05/07	11:45	44PPH	0011 OF 194
07/05/07	11:46	44PPH	0012 OF 194
07/05/07	11:47	45PPH	0013 OF 194
07/05/07	11:48	45PPH	0014 OF 194
07/05/07	11:49	45PPH	0015 OF 194
07/05/07	11:50	44PPH	0016 OF 194
07/05/07	11:51	45PPH	0017 OF 194
07/05/07	11:52	45PPH	0018 OF 194
07/05/07	11:53	45PPH	0019 OF 194
07/05/07	11:54	44PPH	0020 OF 194
07/05/07	11:55	45PPH	0021 OF 194
07/05/07	11:56	44PPH	0022 OF 194
07/05/07	11:57	44PPH	0023 OF 194
07/05/07	11:58	44PPH	0024 OF 194
07/05/07	11:59	45PPH	0025 OF 194
07/05/07	12:00	44PPH	0026 OF 194
07/05/07	12:01	44PPH	0027 OF 194
07/05/07	12:02	44PPH	0028 OF 194
07/05/07	12:04	45PPH	0029 OF 194
07/05/07	12:05	44PPH	0030 OF 194
07/05/07	12:06	44PPH	0031 OF 194
07/05/07	12:07	44PPH	0032 OF 194
07/05/07	12:08	45PPH	0033 OF 194

EXAMPLE PLOT
Date, Time, and PPM Bar Graph

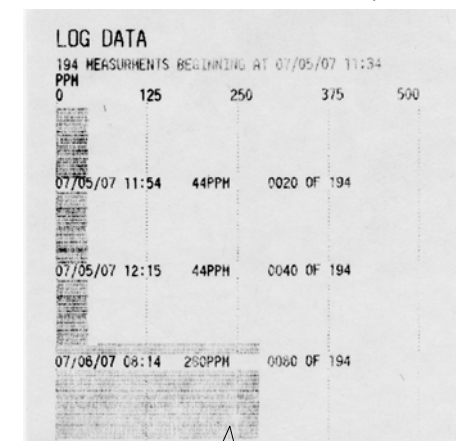

3.17 Downloading Stored Data to a Personal Computer

Using the monitor's **PC DUMP** feature (Page 13), the last 200 SF₆ gas readings that were stored in memory can be downloaded to a personal computer in ASCII text, comma-delimited format, which can then be imported into most spreadsheet programs for analysis.

The following describes how to download data to a computer using Windows® HyperTerminal as the communications program. If a different operating system and/or communications program is being used, then consult the appropriate instruction manuals for those products.

1. Install serial data cable P/N 104-4027 (straight through, 6 foot, DB9 male to DB9 female) between the computer's COM port and the analyzer's RS-232 connector. (For computers having a 25-pin COM port, either use a 25-pin to 9-pin adapter, or use a serial cable with appropriate connectors on each end.)
2. At the computer, start HyperTerminal by doing one of the following:
 - If HyperTerminal has already been set up to communicate with the SF₆ Monitor, then click **Start**, point to **Programs**, point to **Accessories**, point to **Communications**, click **HyperTerminal**, and double-click the file name or icon that has been associated with the SF₆ Monitor.
 - If HyperTerminal has never been run in association with the SF₆ Monitor, then a new HyperTerminal connection needs to be made as follows:
 - a) Click **Start**; click **Run**. In the Run box type "hypertrm.exe" and click **OK**. The **New Connection** dialog box should appear.
 - b) Type in a New Connection Name such as "SF6". Click **OK** to select the default icon (if desired, select a different icon before clicking OK). The **Connect To** dialog box should appear.
 - c) Click the **Connect using** drop-down menu and choose the **COM** port to which the analyzer is connected. Then click **OK** to display the **COM Properties** dialog box for that COM port.
 - d) Set Port Settings to:
 - Bits per second: 19200
 - Data bits: 8
 - Parity: None
 - Stop bits: 1
 - Flow control: None

Then click **OK** to display HyperTerminal's main window.

 - e) Click **File**; click **Save**. This creates a file with an .ht extension in the folder C:\Program Files\Accessories\Hyper Terminal, using the name that was entered in Step b.

3. After HyperTerminal is running: click **Transfer**, click **Capture Text**, and then click **Start** to accept the default drive\directory\filename to which all received data will be stored as an ASCII text file.

Note: By default, the captured text file will be stored on the hard drive at C:\Program Files\Accessories\HyperTerminal\CAPTURE.TXT. If desired, click **Browse** to select a different drive, directory and filename. The next time data is captured, it will be stored under the same location and filename.

Tip: Changing the filename extension to "CSV" (comma separated variable) will allow the file to be directly opened in the spreadsheet program. For example, double clicking the filename CAPTURE.CSV in Windows Explorer will automatically start Microsoft Excel and load the file.

4. From the **Data Display** screen, press both the **Keypad Left** and **Right** buttons at the same time to display the first **Function Menu** screen. Next, use the **Keypad** buttons to move the arrow (>) until it points to **PC-DUMP**, and then press the **ENTER** button to begin the download process.

2ndUNIT	PRINT
PLOT	>PC-DUMP

5. Observe that the SF₆ Monitor's screen goes blank and that HyperTerminal displays the data as it is being received. After all data has been transmitted, the SF₆ Monitor re-displays the **Function Menu** screen.
6. To stop capturing data and save it, click **Transfer**, click **Capture Text**, click **Stop**.
7. HyperTerminal and the connection to the SF₆ Monitor can now be closed.

3.18 Importing Saved Data Into a Spreadsheet

A text file that was created as described in Section 3.17 can be imported into spreadsheet programs that are capable of importing comma-delimited files.

The following describes how to generate a spreadsheet from a comma-delimited text file using Microsoft Excel 2003. If you are using a different spreadsheet program, please refer to its instruction manual for information on how to import comma-delimited text files.

1. Start Microsoft Excel.
2. Click **Data**, **Import External Data**, and **Import Data** to display the "Select Data Source" dialog box.
3. Locate file saved earlier. Select file, then click "Open" to display Excel's "Text Import Wizard."
4. Choose the "Delimited" original data type option and click Next.
5. Check the "Tab," "Comma," and "Space" delimiters and click Finish.
6. Choose "Existing worksheet" or "New worksheet" and click OK to create spreadsheet.

Note: A worksheet must be open in order to import data.

4 Maintenance

4.1 Disassembly

When servicing the parts inside the SF₆ Monitor, disassemble the monitor's metal chassis as follows:

Items Required:

- Medium Phillips head screwdriver

Procedure:

1. Remove monitor and its battery pack from the soft carrying case.
2. Unplug battery pack from monitor.
3. Remove a total of 10 screws from the locations shown in the illustrations below.
4. Carefully separate the metal chassis.

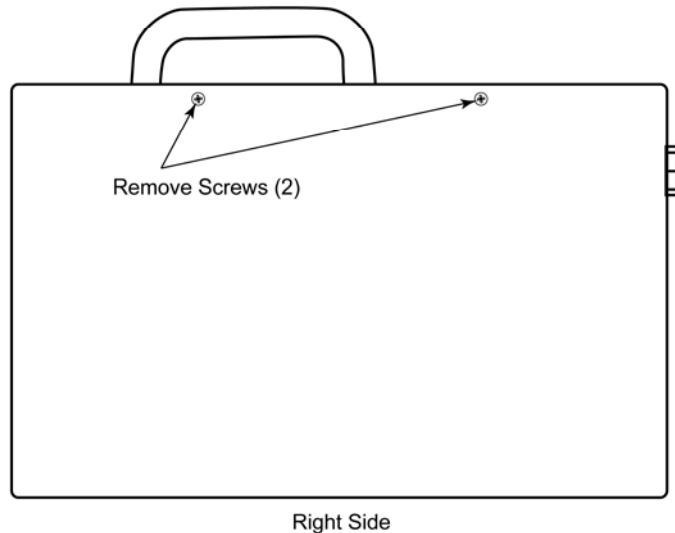
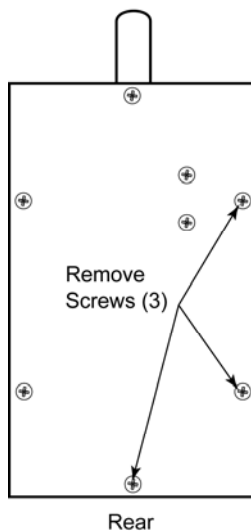
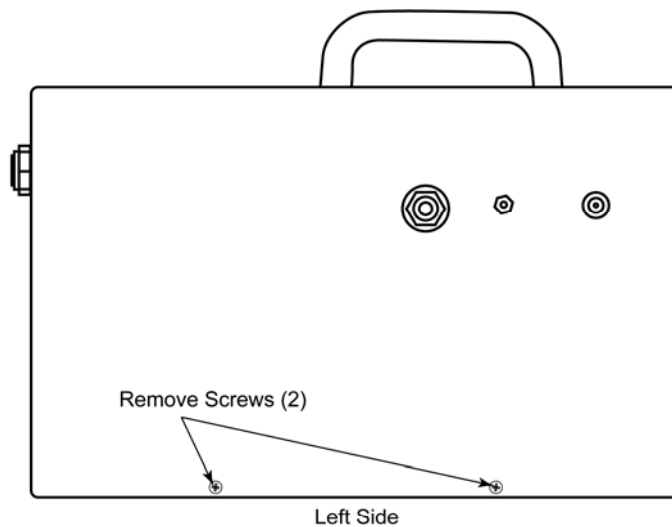
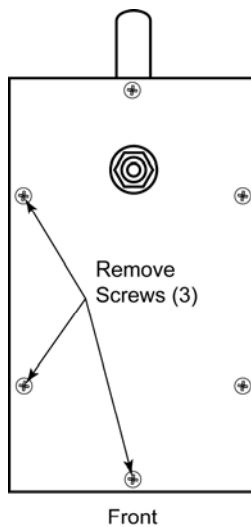

4.2 Internal Particulate / Hydrophobic Filter Replacement

Items Required:

- Replacement filter (P/N 0007-1654)
- Medium Phillips head screwdriver

Procedure:

1. Disassemble the monitor's metal chassis per Section 4.1.
2. See illustration below and locate the internal particulate / hydrophobic filter.
3. Pull off tubing from both ends of filter and remove filter from instrument.
4. Attach tubing to new filter
5. Reassemble monitor.

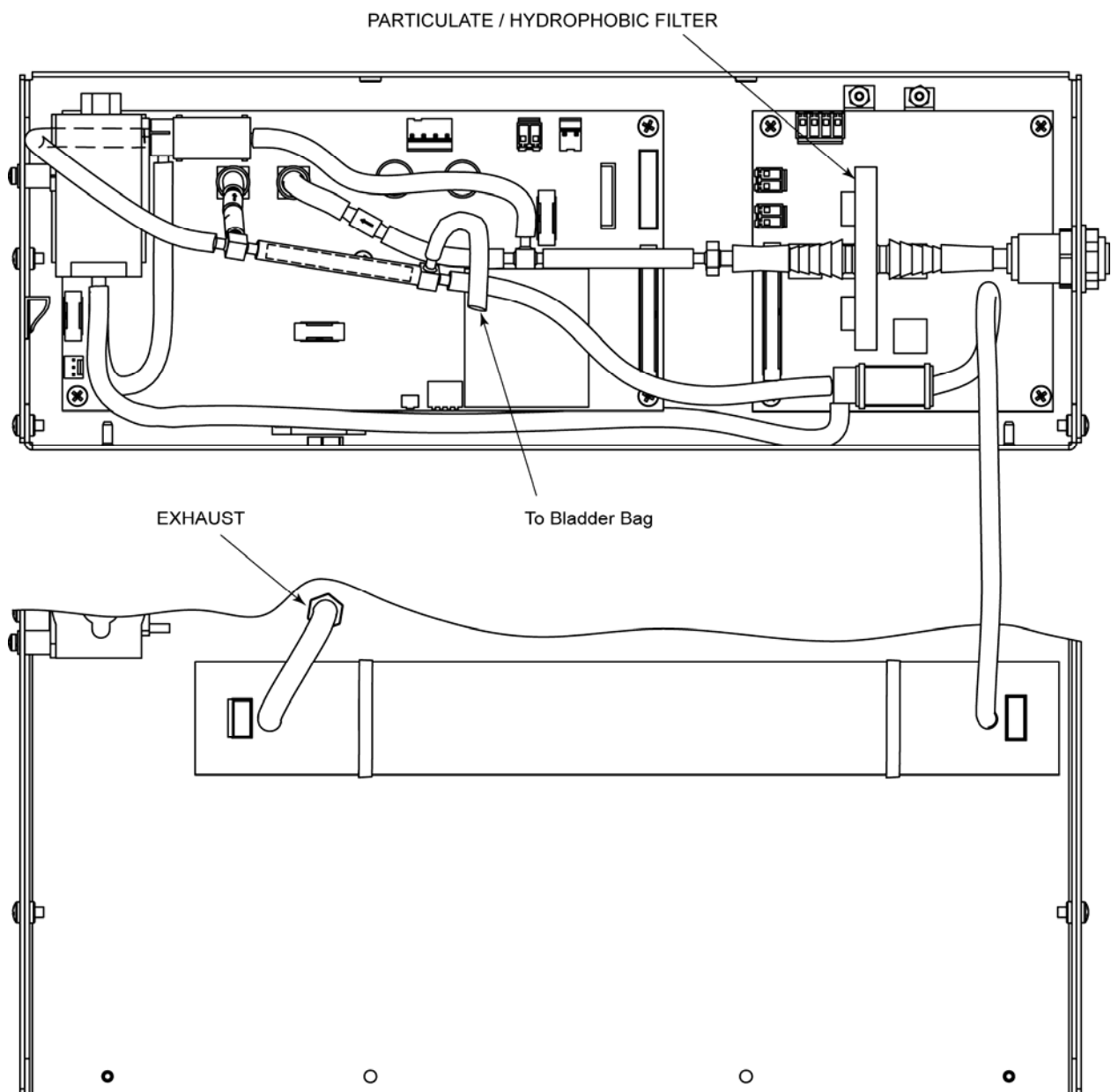

4.3 Flashing Memory

An RS-232 connector, located on the top panel, is used to flash the monitor's memory. This connector is for factory and service technician use only.

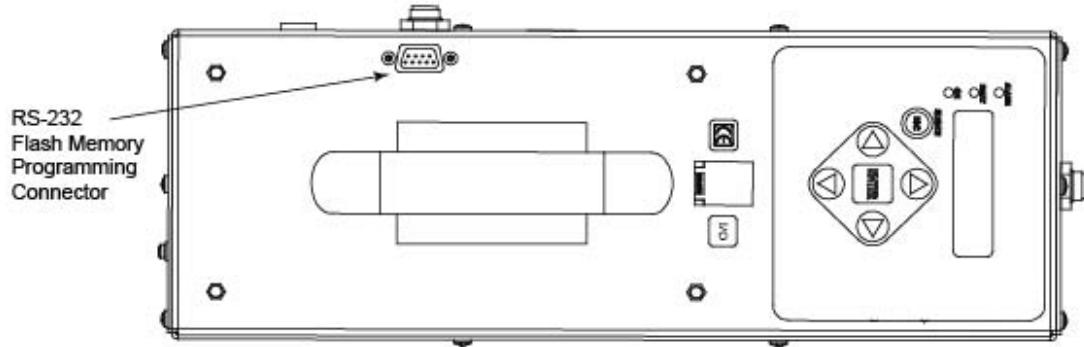

4.4 Bench Replacement

Items Required:

- Replacement IR Optical Bench Kit 3015-4561:
 - IR Bench Assembly 3015-5087
 - Cable Ties (Qty. 2) 3015-2835
 - Instruction Sheet 3015-4526
- Medium Phillips Head Screwdriver
- Small Flat Blade Screwdriver
- Wire Cutter (for removing cable ties)

4.4.1 Removing the IR Bench

1. Review the internal components of the SF6 Portable Monitor shown below before proceeding.

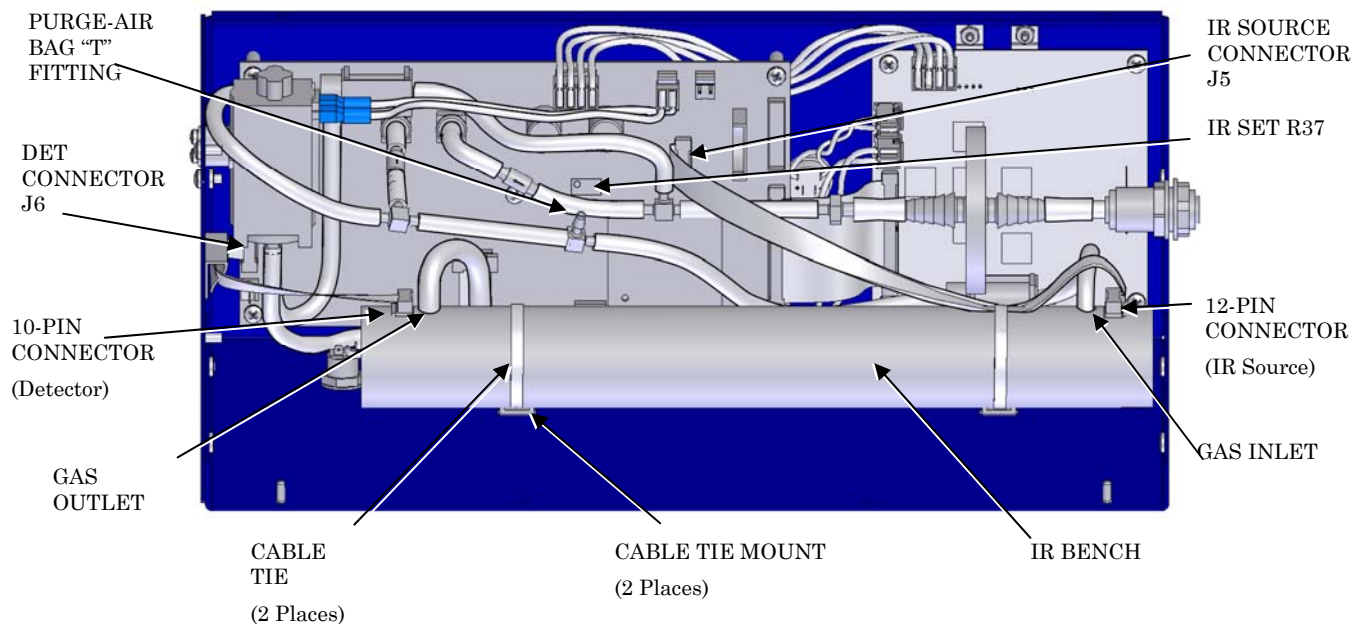

2. Refer to this figure while performing the following steps to remove the old IR bench:
 - a. Disconnect the tubing from the purge-air bag "T"-fitting, and then lay aside the chassis-half containing the purge-air bag.
 - b. Pull the 10-pin and 12-pin electrical connectors from their sockets on the IR bench. Note that these connectors may have been secured in place for shipping purposes with hot-glue or wire ties. As necessary, pry the hot-glue from each connector, or cut off the wire ties.
 - c. Pull the tubing from the gas-inlet and gas-outlet fittings on the IR bench.
 - d. Using wire cutters, cut the two cable ties that secure the IR bench to the chassis, and then remove the bench.

4.4.2 Installing the New IR Bench

3. Perform the following steps to install the new IR bench:
 - a. Remove protective caps from the gas-inlet and gas-outlet fittings on the new IR bench.
 - b. Position the new bench inside the chassis so that the end with the 12-pin electrical connector (IR Source) is located on the *right*, and that the gas fittings are facing upwards.
 - c. Reconnect the tubing that was removed in Step 6c to the gas-inlet and gas-out fittings on the IR bench.
 - d. Plug the 12-conductor ribbon cable from IR SOURCE connector J5 on the main board into the 12-pin IR bench connector.
 - e. Plug the 10-conductor ribbon cable from DET connector J6 on the main board into the 10-pin IR bench connector.
 - f. Using the two cable ties supplied in the kit, secure the bench to the cable-tie mounts on the side wall of the chassis. Note that the 12-conductor ribbon cable is secured in place by positioning it under the cable tie. Cut off any cable-tie excess.
4. Verify the new IR bench is properly secured, and that all tubing and electrical connectors are tight.
5. Reconnect the tubing from the purge-air bag onto its “T”-fitting.
6. Connect the battery pack to the monitor’s battery connector, and then turn ON the monitor.
7. Allow the monitor to warm-up for at least ½ hour before proceeding.

4.4.3 Adjusting IR Bench Emitter Drive Power Level

8. This section explains accessing the IR screen, adjusting the IR source power drive to 450 mW, and then exiting up one level to then adjust the digipot, as described below. First, access the monitor’s set-up mode and display the IR emitter power adjustment screen as follows:
 - a. With the monitor in its MEASURE mode, use the keypad buttons to place the arrow (>) on the display next to the CAL function.
 - b. Press the Right-Arrow and ENTER buttons at the same time to display the revision screen.
 - c. Press the QUIT button to display the set-up screen.
 - d. With the arrow (>) next to the IR function, press the ENTER button to display the IR emitter adjustment screen.
 - e. Change IR emitter drive level to 450 mW by adjusting R 37 clockwise. If R37 is not present (newer models), use the Up/Down arrow keys to adjust the power level to 550 mW.
 - f. Press the ENTER button and then proceed to the next section and adjust the DIGIPOT as necessary.

4.4.4 Adjusting the IR Bench Voltage

9. Enter the monitor's set-up mode and display the IR bench voltage adjustment screen as follows:
 - a. With the monitor in its MEASURE mode, press both keypad Left and Right buttons at the *same time* to display the function menu screen. Then use the keypad buttons to place the arrow (>) on the display next to the DIAG function.
 - b. Press the Right-Arrow and ENTER buttons at the *same time* to display the revision screen.
 - c. Press the ESC button to display the set-up screen.
 - d. With the arrow (>) next to the DIGIPOT function, press the ENTER button to display the IR bench voltage adjustment screen.
10. While observing the IR VOLT reading, use the Up/Down-Arrow buttons to obtain a reading of 4.200 ± 0.100 volts. Note that the DIGIPOT value may vary from what is shown in the display on the right.

```
REV M D Y  
x.xx at HH:MM:SS
```

```
PPM LOG LOG INT  
FAULTS >DIAG
```

```
>DIGIPOT TEMP COS  
P CAL IR
```

```
DIGIPOT=193  
IR VOLT=4.200
```

IMPORTANT! If adjusting the DIGIPOT does not reach 4.2000 ± 0.0500 volts, then return to step 12 to reduce the IR Emitter power by 75 mW and repeat the DIGIPOT adjustment.

11. Press the ENTER button, and then press the ESC button *twice* to exit the monitor's set-up mode.
12. Perform the following *only* if the IR bench voltage cannot be adjusted to within the desired voltage range as described in Step 13:
 - a. While observing the DIGIPOT reading, use the Up/Down-Arrow buttons to obtain a reading of 220.
 - b. While observing the IR VOLT reading, use a small flat blade screwdriver to adjust IR SET potentiometer R37 (see Figure 3) for a reading of 4.200 ± 0.100 volts.
13. Press the ENTER button, and then press the ESC button *twice* to exit the monitor's set-up mode.
14. Upon exiting the set-up mode a purge cycle will be performed; after which, the monitor will automatically return to its MEASURE mode.
15. Turn OFF the monitor and reassemble the chassis using the 10 screws removed in the *Disassembling the Chassis* section.

The monitor can now be placed back into service.

5 Parts and Service

5.1 Replacement Parts & Optional Items

Replacement Parts	
Item Description	Part Number
SF6 Monitor	3015-5148
Battery Pack & Charger	3015-4654
Battery Charge Cable	3015-4405
Replacement Battery	3015-5245
Replacement Charger	3015-5254
Soft Carrying Case with Shoulder Strap	3015-4474
Bladder Bag Kit	3015-5325
Stainless Steel Probe	3015-5326
Filters:	
External Filter	3015-2906
Hydrophobic Filter	0007-1654
External Filter Assembly	3015-5324
Tubing (3 ft)	0003-6182
Replacement Pump	3015-4239
Battery (for main PCB board)	0204-0020
Replacement Bench	3015-4561
Optional Accessories	
Item Description	Part Number
IrDA Printer Kits, Parts, Accessories	
120 VAC (includes printer, 120 VAC adapter, 12V in car charger, belt clip, instruction manual)	0024-1229
230 VAC (includes printer, 230 VAC adapter, 12V in car charger, belt clip, instruction manual)	0024-1230
Thermal Paper Roll	0006-8733
Battery Pack, rechargeable, 7.2V, Li-ion	0024-1244
Cable (DB9 to RJ45)	3015-4214
AC adapter: 120 VAC	0024-1243
230 VAC	0024-1245
12V in car charger	0024-1250

Computer Communications Cable (DB9 male to DB9 female)	0104-4027
--	-----------

5.2 Service Centers

Service and replacement parts can be obtained by contacting any of the following Bacharach Service Centers:

United States

Bacharach, Inc.
621 Hunt Valley Circle
New Kensington, PA 15068
Phone: 724-334-5051
Fax: 724-334-5723
Email: help@mybacharach.com

Canada

Bacharach of Canada, Inc.
20 Amber St. Unit #7
Markham, Ontario L3R SP4
Canada
Phone: 905-470-8985
FAX: 905-470-8963
E-mail: bachcan@idirect.com

Notes: