



HGM IR Bench Replacement Kit 3015-4572

Instruction 3015-4571

Rev. 3 – June 2010

Scope

These instructions describe how to replace the IR bench in the Halogen Gas Monitor (Single-Zone or Multi-Zone).

It is assumed that the user is familiar with the operation of the HGM-SZ and HGM-MZ. If necessary, refer to instruction 3015-4256 (HGM-SZ) and/or instruction 3015-5074 (HGM-MZ) for detailed operation and maintenance information.

Items Required:

- Replacement IR Optical Bench Kit 3015-4572, which includes:
 - IR Bench Assembly: 3015-5086
 - Cable Ties (Qty. 2) 3015-2835
 - Instruction Sheet 3015-4571
- Medium Phillips Head Screwdriver
- Small Flat-Blade Screwdriver
- Wire Cutter (for removing cable ties)

Removing the IR Bench

1. Find the AC power source for the monitor and switch OFF the AC circuit breaker. Ensure that the monitor's front panel green MONITOR ON indicator is OFF.
2. Use a Phillips screwdriver to remove the monitor's two door screws, and then open the door.
3. Take time to familiarize yourself with the internal components displayed on the following page. Figure 1 is a diagram of the HGM-SZ while Figure 2 is a diagram of the HGM-MZ.

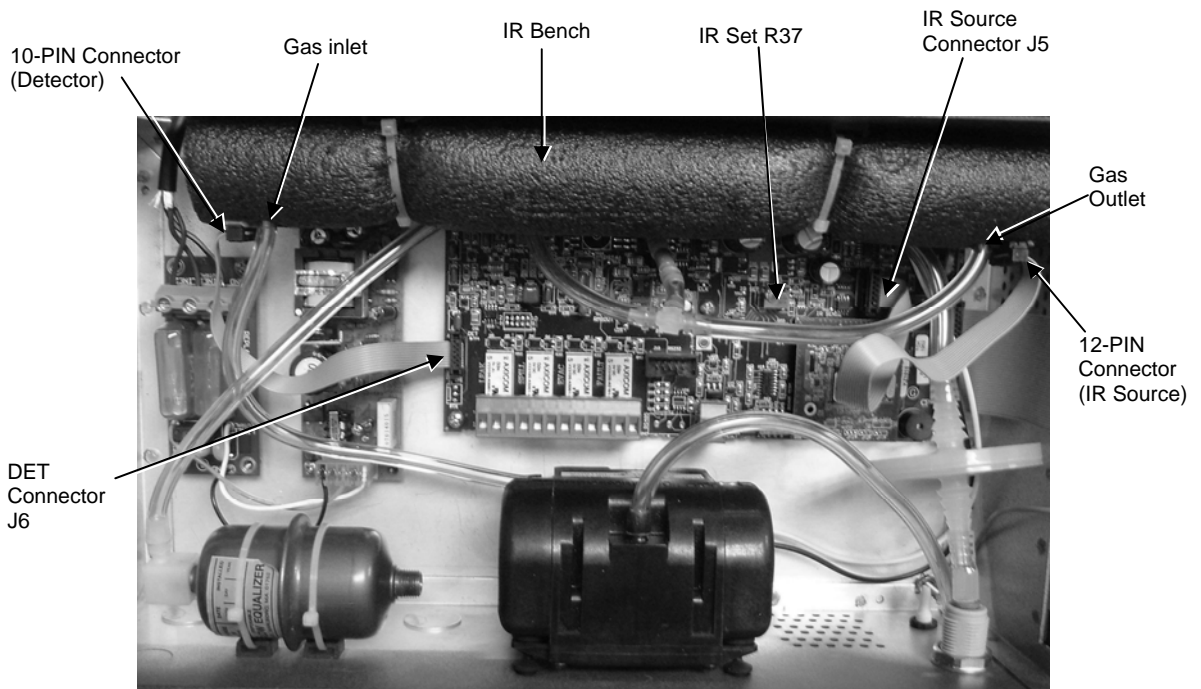

Figure 1: HGM-SZ Components

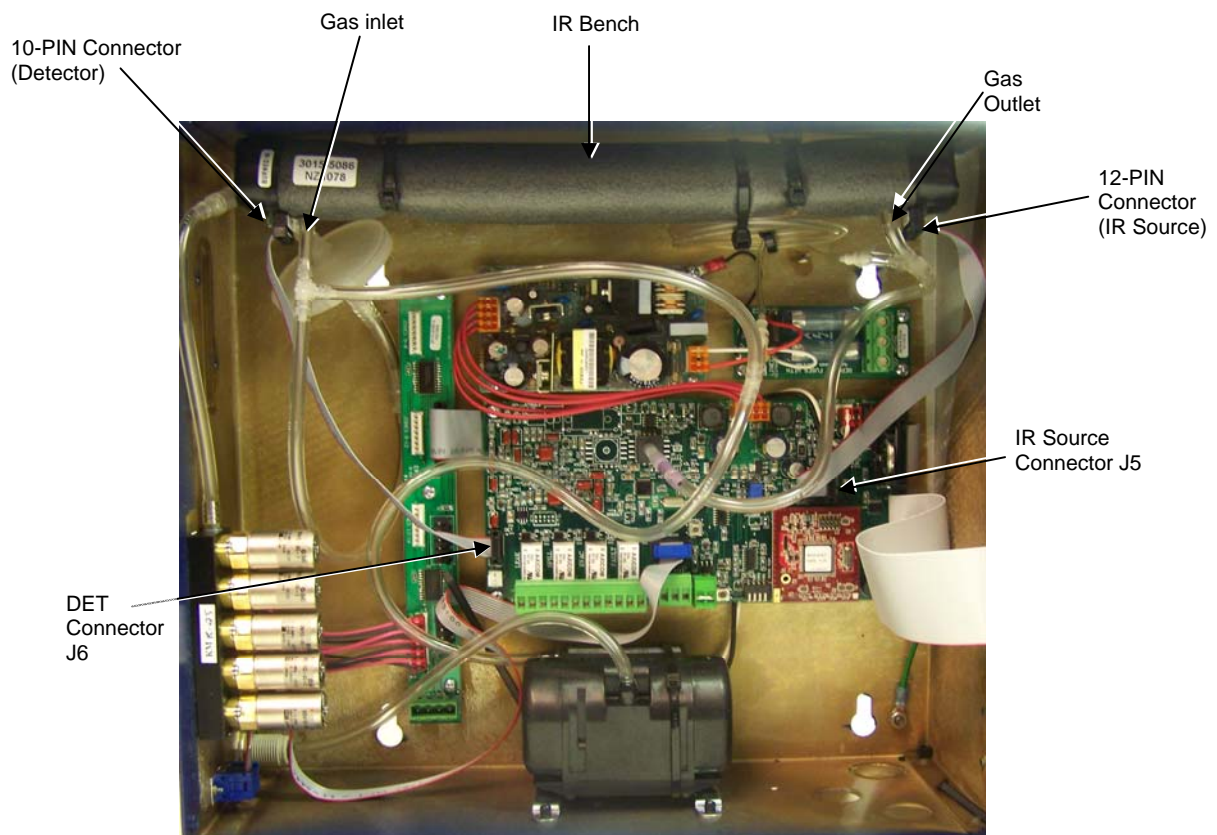

Figure 2: HGM-MZ Components

4. To remove the old IR bench:
 - a. Pull the 10-pin and 12-pin electrical connectors from their respective sockets on the IR bench. Note that these connectors may have been secured with either hot glue or cable ties for shipping purposes. As necessary, carefully remove anything securing the connector then remove the connector.
 - b. Pull the tubing from the gas-inlet and outlet fittings on the IR bench.
 - c. Using wire cutters, cut the two cable ties that secure the IR bench to the enclosure, then remove the bench from the monitor.

Installing the New IR Bench

5. Perform the following to install the new IR bench:
 - a. Remove protective caps from the gas-inlet and gas-outlet fittings on the new IR bench.
 - b. Position the new bench inside the enclosure so that the end with the 12-pin electrical connector (IR Source) is located on the **right** and that the gas fittings are facing towards the monitor's main board.
 - c. Using the two cable ties supplied in the kit, secure the bench to the cable-tie mounts on the side wall of the enclosure. Cut off any cable-tie excess.
 - d. Connect tubing from pump to the IR bench gas-outlet fitting, and connect tubing from purge valve V1 to the IR bench gas-inlet fitting.
 - e. Plug the 12-conductor ribbon cable from IR SOURCE connector J5 on the main board into the 12-pin IR bench connector.
 - f. Plug the 10-conductor ribbon cable from DET connector J6 on the main board into the 10-pin IR bench connector.
6. Check to ensure that the new IR bench is properly secured, and that all tubing and electrical connectors are tight.
7. Turn ON the monitor's AC circuit breaker.

HGM-SZ

This section describes how to proceed if installing a new IR bench in a **HGM-SZ**.

Adjusting IR Bench Emitter Drive Power Level

1. To adjust the IR emitter power level:
 - a. With the monitor in its MEASURE (normal) mode, enter the main menu and use the keypad buttons to place the arrow (>) on the display next "CAL."
 - b. Press the Right-Arrow and ENTER buttons **at the same time** to display the revision screen.
 - c. Press "QUIT" to display the setup screen.
 - d. Place the arrow (>) next to the "IR" and press "ENTER."
 - e. Observe the "MW" reading in the lower-right portion of the screen. Change this IR emitter drive level to 450 mW by using the Up/Down arrow buttons.
 - f. Press "ENTER" to return to the setup screen.

Adjusting the IR Bench Voltage

1. To adjust the IR bench voltage:
 - a. With the monitor in its MEASURE (normal) mode, enter the main menu and use the keypad buttons to place the arrow (>) on the display next "CAL."
 - b. Press the Right-Arrow and ENTER buttons **at the same time** to display the revision screen.
 - c. Press "QUIT" to display the setup screen.
 - d. Place the arrow (>) next to the "DIGIPOT" and press "ENTER."
2. Observe the IR VOLT reading. Use the Up/Down arrow buttons to obtain a reading of 4.200 ± 0.100 volts. Note that the DIGIPOT value is not important as long as the voltage is 4.200 ± 0.100 volts.

```
>DIGIPOT MODEL  
P CAL IR
```

```
DIGIPOT=193  
IR VOLT=4.200
```

```
SILENCE ZONETMP  
SQUELCH >CAL
```

```
REV M D Y  
x.xx at HH:MM:SS
```

IMPORTANT! If adjusting the DIGIPOT does not reach 4.200 ± 0.100 volts, return to Step 1 of the previous section to lower the IR emitter setting. If the IR emitter setting is 450 ± 20 mW, adjust the new IR emitter setting to 375 ± 20 mW. Repeat the DIGIPOT procedure with the new IR emitter setting.

3. Press "ENTER" to save this setting and then press "QUIT" **twice** (2x's) to exit the monitor's setup mode.
4. A purge cycle will be performed upon exiting the setup mode and then the monitor will automatically return to its MEASURE mode. If there are no faults the new IR bench has been successfully installed.
5. Close and secure the enclosure door using the screws removed in Step 2.
6. The monitor can now be placed back into service.

HGM-MZ

This section describes how to proceed if installing a new IR bench in a **HGM-MZ**.

Adjusting IR Bench Emitter Drive Power Level

1. To adjust the IR emitter power level:
 - a. With the monitor in its MEASURE mode, enter the main system setup menu.
 - b. Enter Service Mode by highlighting "Service Mode" and pressing "ENTER" **twice** (2x's).
 - c. Navigate to "SYSTEM" and press "ENTER" to enter the system setup screen (while in Service Mode).
 - d. Navigate to "More" in the bottom-right corner and press "ENTER."
 - e. Navigate to "IR DIGIPOT" in the bottom-right and press "ENTER."
 - f. Observe the "MW" reading the in lower-right portion of the screen. Change this IR emitter drive level to 450 mW by using the Up/Down arrow buttons.
 - g. Press "ENTER" then "ESC" to return to the setup screen.

Adjusting the IR Bench Voltage

1. To adjust the IR bench voltage:
 - a. With the monitor in its MEASURE mode, enter the main system setup menu.
 - b. Enter Service Mode by highlighting "Service Mode" and pressing "ENTER" **twice** (2x's).
 - c. Navigate to "SYSTEM" and press "ENTER" to enter the system setup screen (while in Service Mode).
 - d. Navigate to "More" in the bottom-right corner and press "ENTER." The following screen will be displayed.

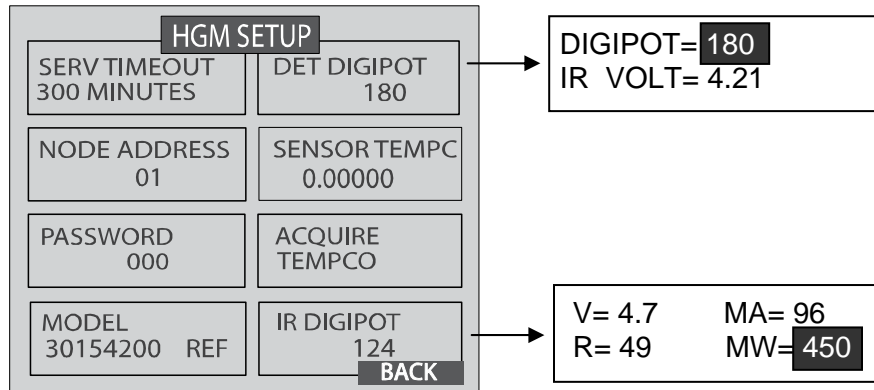

- e. Navigate to "DET DIGIPOT" in the top-right and press "ENTER."
2. Observe the IR VOLT reading. Use the Up/Down arrow buttons to obtain a reading of 4.200 ± 0.100 volts. Note that the DIGIPOT value is not important as long as the voltage is 4.200 ± 0.100 volts.

IMPORTANT! If adjusting the DIGIPOT does not reach 4.200 ± 0.100 volts, return to Step 1 of the previous section to lower the IR emitter setting. If the IR emitter setting is 450 ± 20 mW, adjust the new IR emitter setting to 375 ± 20 mW. Repeat the DIGIPOT procedure with the new IR emitter setting.
 3. Press "ENTER" to save this setting and then press "ESC" **once** (1x) to exit the monitor's setup mode.
 4. Navigate to "IN SERVICE" and press "ENTER" **twice** (2x's) to exit Service Mode. Press "ESC" to return to the main measuring screen.
 5. A pressure check and purge cycle will be performed upon exiting Service Mode and then the monitor will automatically return to its MEASURE mode. If there are no faults the new IR bench has been successfully installed.
 6. Close and secure the enclosure door using the screws removed in Step 2.
 7. The monitor can now be placed back into service.



Headquarters:

621 Hunt Valley Circle, New Kensington, PA 15068
Ph: 724-334-5000 • Fax: 724-334-5001 • Toll Free: 1-800-736-4666
Website: www.mybacharach.com • E-mail: help@mybacharach.com